

**TACTICS, TECHNIQUES, AND PROCEDURES
FOR THE
SENSOR PLATOON**



DISTRIBUTION RESTRICTION: Approved for public release. Distribution is unlimited.

Tactics, Techniques, and Procedures For The Sensor Platoon

Table of Contents

	Page
CHAPTER 1 Mission and Organization	1-1
CHAPTER 2 Platoon Leader Planning and Command, Control, and Communications	2-1
CHAPTER 3 Section Employment	3-1
CHAPTER 4 Sensor Section Emplacement, Survivability, and Operations.....	4-1
CHAPTER 5 Identification and Reporting	5-1
APPENDIX A Responsibilities	A-1
B Observation Techniques	B-1
C Determining Direction in the Field	C-1
D Stealth	D-1
E Position Security	E-1
F Communications Planning and Troubleshooting	F-1
G Sensor Employment	G-1
H Manual SHORAD Control System	H-1
Glossary	Glossary-1
References	References-1

CHAPTER 1

Mission and Organization

This chapter discusses the mission and organization of the ADA sensor platoon. The mission of the ADA sensor platoon is to provide alerting and early warning data on aircraft to users throughout the battlefield. The sensor platoon replaces the forward area alerting radar (FAAR) platoon in ADA battalions.

MISSION DESCRIPTION

The ADA sensor platoon accomplishes its mission by acquiring and identifying aircraft and alerting FAAD weapons systems to hostile targets in their area of responsibility. In addition, ADA sensor platoon early warning reports help protect friendly aircraft from fratricide. The ADA sensor sections are deployed in support of the reconnaissance and surveillance (R&S) plan to observe critical named areas of interest (NAIs). The sections are primarily deployed where they can best protect the division's area of operations (AO). ADA sensor sections position themselves where they can best cover designated NAIs while maintaining their security. Positioning the ADA sensor sections across the FLOT is risky and must be METT-T driven. Crossing the FLOT exposes the sensor sections to dangers they are not currently equipped for and requires extensive coordination for passages of line, resupply, and return. However, mission requirements will dictate their actual position. The sensor sections' purpose is surveillance; therefore, they will engage ground or aerial forces only in self-defense or when ordered. ADA sensor sections rely on stealth and experience to infiltrate, escape, evade, and survive. The information gathered by the sections and passed to the ADA commander helps the commander mass ADA fires at the right place and time.

ADA SENSOR PLATOON ORGANIZATION

The ADA sensor platoon is organic to both divisional and nondivisional AD units. The sensor platoon supports the missions as dictated by the AD battalion commander through the S2 and S3. The organization of the sensor platoon is structured to support those missions. The following diagram shows the elements of a sensor platoon and its organization.

Each division has one platoon of ADA sensors in the headquarters and headquarters battery (HHB) of the ADA battalion. The platoon has six sensor sections. Each ADA sensor section has three members: a section chief, a sensor operator, and a driver/operator. The section is transported by an M1038, high-mobility, multipurpose wheeled vehicle (HMMWV).

[Figure 1-1.](#)

SENSOR PLATOON

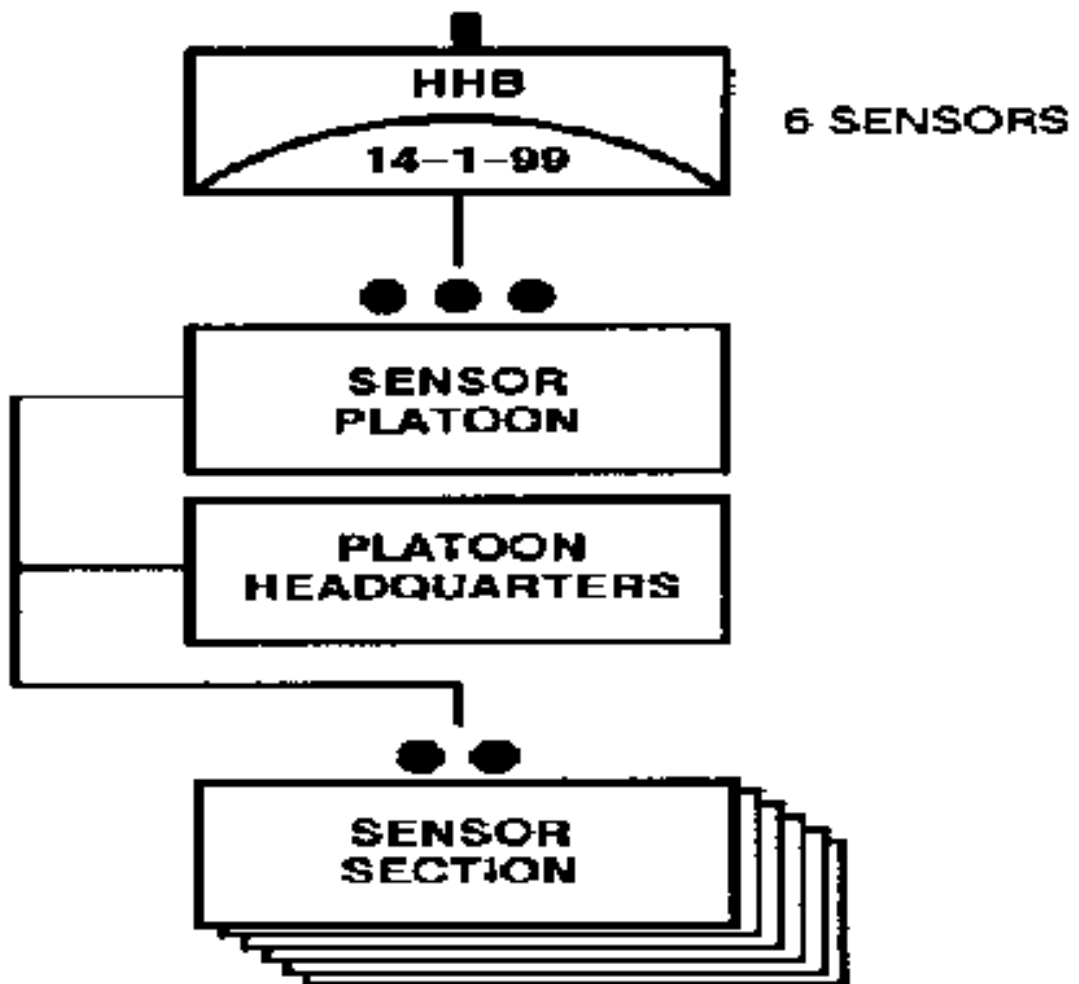

Figure 1-1

CHAPTER 2

Platoon Leader Planning and Command, Control, and Communications

This chapter discusses the planning, command, control, and communications (C3) methods for the employment of the sensor platoon. ADA sensor tactics depend upon a platoon leader and section chiefs who can carry out mission-type orders on a constantly changing battlefield. The ADA sensor platoon leader must understand the situation, then prepare and execute a plan.

PLANNING

The platoon planning cycle follows the military decision-making process. It begins with the receipt of a new mission. Time is the most critical resource when a new mission is received. First, the platoon leader thinks through the task. He coordinates with his platoon sergeant (PSG), and keeps him abreast of the situation. The platoon leader plans the use of available time by backward planning from the mission objective. A buffer is built into the planning sequence to allow for unexpected delays.

ISSUE WARNING ORDER

The platoon leader issues a warning order to the platoon immediately upon receipt of a warning order from higher headquarters. He tells his platoon what the mission is, when it is to take place, what initial preparations must be made, and when the detailed operation order (OPORD) will be issued. The warning order will normally be issued orally, either in person or by radio communications.

INITIATE MOVEMENT

Movement will be governed by standing operating procedures (SOPs). Sections move tactically to the platoon rally points and perform individual and section precombat inspections. The platoon leader immediately goes to the ADA battalion tactical operations center (TOC) and becomes involved in the decision-making process. He keeps the PSG or senior section chief informed of any changes to the mission. The PSG conducts the precombat inspections and maintains contact with the platoon leader to adjust to any changes in the mission.

ADA CONCEPT

The ADA S3 will show the initial decision support template (DST) and decision support matrix (DSM) to the sensor platoon leader. The ADA portion of the initial DST and DSM may be general, dependent on the availability of brigade and task force graphics. The ADA DST and DSM will continue to be adjusted

based on brigade or task force rehearsals. This initial DSM (see the ADA Decision Support Matrix illustration on page 2-2) is intended to be a concept, giving guidance to the platoon leader on the following:

- The commander's intent.
- ADA concept.
- Aerial intelligence preparation of the battlefield (IPB).
- A2C2 plan.
- Mission time.
- A/L support plan.

Based on these factors, the platoon leader must pick general positions for the sensor sections which best support the ADA scheme of maneuver and the ADA R&S plan as developed by the S2. It is imperative that the sensor platoon leader make direct coordination with the ADA battalion commander to understand his intent. As the sensor platoon leader prepares for the mission, he should go through all established troop-leading procedures along with the ADA battery commanders.

[Figure 2-1.](#)

TENTATIVE SENSOR PLAN

The platoon leader must understand the ADA battalion and supported unit mission and the commander's intent. In addition, he must know what is happening around him and anticipate what will happen next; for example, changing from defense to offense. He must look at the overall tactical picture. The sensor plan is designed for the best use of limited sensor sections available to cover critical NAIs. Continuous updating of the IPB will aid in providing an effective and flexible sensor plan to observe the NAIs. To develop a collection plan, the platoon leader must perform several functions.

Analyze Mission, Intent, Situation, and Assist in Developing the R&S Plan

The S3 identifies critical assets in time and space by phases of the battle based on his coordination with the platoon leader. The platoon leader assists the S2 in developing the R&S plan by using mission, enemy, terrain, troops, and time available (METT-T), the commander's intent, knowledge of the enemy, and the aerial IPB. Estimating the situation is a constant, cumulative process. Using this estimate, the S2, working with the platoon leader, develops a concept for ADA coverage for each maneuver course of action. See Appendix A for specific responsibilities.

Develop Best Alternative for Coverage

A quick mental war-gaming of surveillance options versus probable enemy actions helps weigh various factors and select the best alternative. The platoon leader considers the following factors when selecting sensor section positions:

- Are the sections task-organized to specific supported units or ADA batteries?
- In the offense, are sensor sections concentrated in the area of the main effort, and will the sections effectively cover the NAIs?
- In the defense, are sensor sections concentrated in the area of the suspected enemy main attack, and do they cover the NAIs?

- Are the air avenues of approach on the division flanks covered?
- Are sensor sections overlapping within 10 to 15 kilometers of each other to ensure surveillance coverage and to minimize dead space caused by terrain masking?
- Are sensor sections no closer than 2 kilometers from each other and within 5 kilometers of a high-power radio frequency (RF) source of the same or similar frequency?

Select Section Positions

Once the platoon leader has obtained the maneuver graphics, obstacle plan, and has war-gamed the options, he then selects the general section positions. Section positions should meet the following requirements:

- Preselected withdrawal routes. Identify friendly obstacles and preplanned positions, if retrograde operations become necessary. Preplan artillery fires to enhance survivability.
- Rally points designated for loss-of-contact contingencies.
- Alternate entrance and multiple-exit routes selected.
- Ability for communications with higher, lower, and adjacent units. At a minimum, have two radios that are man-transportable to provide flexibility.
- Platoon command post (CP) centrally located with respect to the platoon.

Plan for Continuous Operations

A plan must be developed for duty rotation and shift work. The platoon leader is responsible for the planning and executing 24-hour operations. **Work schedule.** When the ADA sensor section is emplaced and operational, work schedules should be mission-dependant. The section members need to be rotated through the manual labor positions followed by a rest period, if possible. Work schedules are stated in hours, 4 hours of work and 4 hours of rest. Rest means sleep or the absence of duties. **Sleep plan.** It is unlikely that a flawless work schedule during the heat of battle will be feasible. However, a strictly enforced sleep plan is vital when possible. The goal is for each soldier to get a minimum of 4 hours of sleep each 24-hour period.

Brief R&S Plan

The ADA battalion S2 will brief the battalion commander to receive approval of the R&S plan. At the time of the briefing, the platoon leader should backbrief the battalion commander and the S2 and S3 to verify understanding of the commander's intent and the overall plan, and to present anticipated problems and get a commitment for support.

Complete the DSM

The platoon leader prepares his decision support matrix for the section briefing.

Brief Sections

The platoon leader prepares the platoon fragmentary order (FRAGO). The FRAGO and execution matrix are briefed to the sections to ensure that all members of the platoon are knowledgeable of the mission.

PLATOON LEADER COORDINATION

The platoon leader conducts thorough initial coordination with the ADA staff to avoid problems or misunderstandings in the future. Since he participated in the commander's initial planning session, he becomes part of the staff's planning session.

S2 Section

The platoon leader coordinates with the S2 to obtain the IPB products and the R&S plan. Specifically, the platoon leader must know where the expected air avenues of approach are with any NAIs, target areas of interest (TAIs), and or decision points the S2 has recommended. He also must know the priority intelligence requirement (PIR) and search times for critical NAIs. IPB is the critical tool to help the platoon leader estimate when and where the enemy will be. This estimate helps the ADA sensor sections find the enemy and the ADA gunners to destroy him. Predicting how the enemy aircraft will approach a target is the most difficult part of the IPB. The inherent flexibility of aircraft to avoid the effects of terrain makes prediction difficult. The best method for determining an air avenue of approach uses an analysis of somewhat fixed factors. These factors include the following:

- The known or suspected locations of enemy airfields and staging areas.
- The location of friendly assets (enemy targets).
- The preference of aircraft commanders for direct routes; the further an aircraft flies, the more fuel it needs and the less ordnance it can carry.
- That aircraft are limited assets that are employed quickly to increase sortie generation.
- Aircraft will use more terrain masking and adjust maximum and minimum ceilings, as locations of friendly air defenses are found.
- The air avenue of approach is more predictable closer to a target.

The S2's designated NAIs focus the sensor platoon surveillance effort in large areas of operation. By knowing what the enemy can do (for example, type of aircraft) and comparing it with what he is doing (doctrine and activity), the S2 may predict what he will do next. NAIs are locations normally overlooking air avenues of approach (AAAs) where the S2 expects or estimates the enemy will be. A specific NAI is designated to confirm or deny a specific activity or course of action. Sensor sections cover NAIs to provide early warning information to friendly forces and timely reports to confirm or deny the S2 estimate of what the enemy will do next. The S2 and air battle management operations center (ABMOC) listen to sensor section reports from many NAIs. Using these reports and coordination with the S3 help to form the "picture" for the commander. Aerial NAIs normally become TAIs depending upon the type and number of enemy present, and the presence of ADA fire units nearby. NAIs which are important to the ADA S2 and sensor section include the following:

- Enemy drop zones (DZs).
- Areas masking friendly radar coverage.
- Projected forward area rearm/refuel point (FARP) location.

TAIs that are important to the ADA S2 and sensor section include the following:

- Enemy forward alighting area (FAA).
- Enemy forward air controller (FAC).
- Enemy division artillery groups (DAGs).
- Enemy landing zones (LZs).

- Helicopter low-level avenues of approach and choke points. The ADA S2 may not be able to cover all NAIs with the ADA sensor platoon and may need to get help from the supported force. He also integrates his plan with the division or corps G2 to avoid duplication of effort while still maintaining control of the ADA sensor platoon. The S2 develops the R&S plan in conjunction with the S3 and the sensor platoon leader. The sensor platoon leader positions the sensor sections. ADA battalion commander PIRs may include, but are not limited to, the following:
- The type and number of aircraft observed in the vicinity of specific NAIs.
- Enemy ground troop or vehicular movements seen.
- Control centers or command vehicles encountered.
- Type and amount of ordnance used by enemy aircraft.
- Identifying markings on enemy aircraft.
- New variations in ground or air vehicles.
- NBC activities.

S3 Section

The sensor platoon leader coordinates with the operations officer to determine the commander's intent, to obtain the DST, the DSM, and scheme of maneuver. He obtains the OPORD graphics for the upcoming operation. The S3 coordinates for section positions and terrain management.

S4 Section

The platoon sergeant manages the logistics status of the platoon. The PSG coordinates with the S4 section while the platoon leader coordinates with the S3. The PSG determines the location of the combat trains to coordinate the resupply of the platoon using the logistics package (LOGPAC) system. He resolves any supply problems encountered on the administration/logistics (A/L) net. If problems arise at the combat trains, the PSG advises the platoon leader so he can attempt to resolve resupply problems with the S4.

ISSUE THE FRAGMENTARY ORDER

When issuing the FRAGO, the platoon leader makes sure that each soldier knows how the platoon is expected to accomplish the mission and how he fits into the plan. There are different techniques for issuing a FRAGO from using a sand table to a terrain walk on the actual battlefield. The important thing is that every soldier understands the platoon leader's intent for accomplishing the mission. The platoon leader should brief the senior section chief and sections using the execution matrix and the FRAGO. The section chiefs should transpose all the appropriate graphics and the execution matrix onto their maps. The backbrief method ensures the commander's intent is understood and clears up any misunderstandings.

The platoon should rehearse the operation using a map, sand table, or the actual terrain whenever possible. Simple rehearsals involve soldiers backbriefing individual duties and the platoon leader asking additional questions. Walk-through and reporting rehearsals also should be conducted. The PSG will verify precombat inspections by the section and supervise rehearsals. The sections should then begin movement.

EXECUTE AND SUPERVISE

Check and double-check the squads. The best plan may fail if not supervised.

PLANNING REMINDERS

The platoon leader's planning ensures that his sections provide the information needed. Use the following reminders to help in making the plan:

- Unless otherwise stated, plan surveillance coverage during the brigade preparation phase for a 24-hour operation. Rehearsing the plan is the best way to achieve success.
- Integrate the sensor plan into an execution matrix according to the ADA plan phases.
- Be aggressively involved in the planning process.
- Plan platoon rally points.
- Create platoon graphics in addition to battalion graphics, if needed.
- Get backbriefs.
- Complete the sensor plan portion of ADA DSM.
- Establish rapport with the supported task force and understand their TOC operations.
- Rehearse limited visibility contingency, when appropriate.
- Ensure section chiefs understand commander's intent and your intent to support the battalion.
- Time is critical. Remember the 1/3-2/3 rule. That is, use 1/3 of the time available for planning and 2/3 of the time for subordinate's planning and execution.

COMMAND AND CONTROL

ADA sensor sections are under the operational control of the ADA sensor platoon leader. The sensor platoon leader works directly for the ADA battalion commander, just as a maneuver scout works directly for the force commander. Control will normally be exercised by the ADA S3 in coordination with the S2. Normally, the ADA sensor platoon is given a general support (GS) mission, but it may be given a direct support (DS) mission to firing battery. Command and support relationships are structured to accomplish the supported force objectives.

GENERAL SUPPORT

When the ADA sensor sections are in a GS role, they are a battalion asset with a GS mission to the division or corps. The platoon leader works for the ADA battalion commander to accomplish the mission.

DIRECT SUPPORT

In this method, two ADA sensor sections are allocated as a minimum to each ADA battery supporting a brigade or task force operation. This affords a continuous coverage capability. One of the ADA sensor sections can remain in position while the other displaces. The supported unit has the final determination on the employment of ADA sensor sections. He makes this determination using the following factors:

- Deployment of supported forces.

- Deployment of fire units.
- The enemy threat, both air and ground.
- Terrain: elevation, hills, valleys, water, et cetera.
- Electronic warfare environment.

REDUNDANCY

All command and control (C2) must be redundant due to the distances involved. This prevents lapses in the early warning coverage and ensures that aircraft are spotted.

CONTINUOUS OPERATIONS

The platoon leader must recognize and exercise some degree of control over each section's work schedule to prevent fatigue from degrading section efficiency. The section's performance and efficiency will normally begin to deteriorate after 14 to 18 hours of continuous work and reach a low point after 22 to 24 hours. After 24 hours of continuous duty, degradation of the section's performance is evident.

ADA SENSOR EMPLOYMENT GUIDELINES

The ADA sensor platoon leader deploys his sections to provide continual ADA surveillance coverage of the supported forces' area of operations. The sections are employed according to the sensor plan to develop the air picture by providing maximum coverage of the most likely AAAs and NAIs. The sensor sections are also emplaced to avoid direct observation. High- to medium-altitude air defense (HIMAD) radar dead zones may require surveillance coverage by the sections. Dead zones are areas that prevent radar search and include hills, valleys, mountain passes, and low areas.

ADA Sensor Sections in the Defense

In the defense, maneuver forces prepare and occupy fortified, covered, and concealed positions with ADA providing air defense. The ADA sensor sections supporting defensive operations require protective coverage and hardening of their locations. Each section should also have a hide location. The location must be carefully selected based on METT-T, the sensor plan, and the employment guidelines. The platoon leader must ensure the sections are not located in engagement areas and that the division A2C2 element and brigade fire support element (FSE) know the ADA sensor section locations (especially in cross-FLOT operations). In defensive situations, the sensor platoon will normally be GS to the division or corps and the ADA sensor sections will be positioned and coordinated by the S3. He will orient on air avenues of approach and possibly cover enemy LZs within the area of operations. However, manning considerations may dictate supported unit asset to cover selected NAIs. Sensor coverage is planned to ensure the ADA fire units have alert and early warning data in enough time to destroy the enemy. METT-T could require that the ADA sensor sections be positioned close to the FEBA (2 to 5 kilometers). The platoon leader will ensure that the ADA sensor section is not left behind if the supported force moves from its original position.

ADA Sensor Sections in the Offense

Movement to contact, hasty attacks, deliberate attacks, pursuit, and exploitation are the offensive operations used by the division. The supporting ADA fire units and the ADA sensor sections must move

continuously to ensure overwatch protection of the forward elements. Regardless of the operation, the ADA sensor sections will be positioned to provide EW to the force's main effort, protecting the flanks of the movement. If more than one ADA battery is supporting the brigade making the main attack, the ADA battalion will control the ADA sensor sections' movement.

COMMUNICATIONS

The platoon leader should establish a sensor platoon/section transmission schedule (for C2) before deployment. Each ADA sensor section must establish communications with the sensor platoon leader and the ABMOC/BNTOC. Current radio allocations allow the section to operate on two radio nets (AM and FM). The AM net is the ADA sensor net, which is used to furnish EW, NAI, TAI, and AAA information to the ABMOC. The FM radio net is a command net. This net is normally the sensor platoon net, but it is used to transmit directed EW on the supporting ADA organizational command net. When the TSOP requires it and for EW redundancy, the FM radio can be used to transmit directed EW data to supported units.

DIRECTED EARLY WARNING AND LOCAL AIR DEFENSE WARNING

Directed early warning is used to alert a particular unit or units or area of the battlefield. Directed EW defines the local air defense warning (LADW), states whether the aircraft are friendly or unknown, provides a cardinal direction, and if known, states the most likely affected asset(s) within the local maneuver force. For example, if an EW source reports four enemy rotary-wing aircraft inbound from the east, and 1st Brigade is attacking along the eastern axis during a maneuver force attack, the sensor platoon leader should report an LADW and directed EW message: "Dynamite! Dynamite! Four HINDS from the east against Axis Blue!" Dynamite is the LADW that alerts the maneuver force to an attack and that response must be immediate. LADWs may differ from unit to unit and the ADA sensor platoon leader must read the division TSOP to learn the proper LADWs. Directed EW must be quick, simple, and redundant. It is imperative that all units, including maneuver units, receive directed EW, especially those units that have limited ADA coverage. Use of grids and manual SHORAD control system (MSCS) at the ADA sensor section level may be impractical and time-consuming during a battle. However, MSCS is still a valid procedure and may be used if time permits. LADWs are designated as Dynamite, Lookout, and Snowman (see the following illustration). They parallel air defense warnings (ADWs), but the level of warning is chosen by the senior ADA representative to the maneuver force. They are used in directed EW to alert a local force of impending air attack. They should be incorporated into the local TSOP, explaining what response is desired by the supported unit when an LADW is broadcast. For example, when Dynamite precedes an ADW Red, the maneuver forces stop to increase passive air defense and predesignated vehicles prepare to engage with a combined arms air defense (CAAD) response. The response desired by the maneuver force is unique to METT-T.

LOCAL AIR DEFENSE WARNINGS

DYNAMITE - Aircraft are inbound or are attacking locally. Response is immediate.

LOOKOUT - Aircraft are in the area of interest but are not attacking, or are inbound, but there is time to react.

SNOWMAN - No aircraft pose a local threat at this time.

AIR DEFENSE WARNINGS

Air defense warnings are established by corps or the regional air defense commander. In no case can the battery ADW be lower than the overall ADW issued by higher authority; however, it can be more restrictive. When received, LADWs apply to the entire force and must be disseminated to every soldier within the TF. At the brigade level and below, EW is disseminated over redundant nets along with LADWs. The following Air Defense Warnings illustration provides general information of the air threat.

AIR DEFENSE WARNINGS

ADW Red - Attack by hostile aircraft or missiles is imminent or in progress. This means that hostile aircraft or missiles are within a respective area of operations or in the immediate vicinity of a respective area of operations with high probability of entry thereto.

ADW Yellow - Attack by hostile aircraft or missiles is probable. This means that hostile aircraft or missiles are en route toward a respective area of operations, or unknown aircraft or missiles suspected to be hostile are en route towards, or are within, a respective area of operations.

ADW White - Attack by hostile aircraft or missiles is improbable. ADW White can be declared either before or after ADW Yellow or ADW Red.

COMMUNICATIONS EQUIPMENT

To achieve its communications requirements, the ADA sensor section must have the appropriate communications equipment. The ADA sensor section operates the FM radio set AN/VRC-46 and the AM radio set AN/GRC-213. The objective ADA sensor program calls for the current AN/VRC-46 to be replaced by the AN/VRC-92 SINGARS radio. The AN/VRC-92 is a vehicular-mounted, dual, long-range radio that has a two-net capability.

SIGNAL OPERATION INSTRUCTIONS

The signal operation instructions (SOI) provides the ADA sensor section the information required to practice radio operating procedures. The section leader will carry and have responsibility for the SOI because he will be operating on the command and EW nets. Because of their sensitivity nature, SOI and codes have special handling procedures prescribed to lessen the possibility of unauthorized disclosure. Only the necessary items of an SOI should be included in extracts carried by the section. Critical information includes the following:

- Radio call signs and frequencies.
- Sound signals.
- Pyrotechnic and smoke signals.
- Signs and countersigns.
- Operations codes.
- Authentication system.
- Radio frequency assigned.

ELECTRONIC COUNTERMEASURES AND ELECTRONIC COUNTER-COUNTERMEASURES

Electronic countermeasures are all the means and methods an enemy uses to deny the use of the electronic spectrum to the force. Electronic counter-countermeasures (ECCM) are measures used to reduce or eliminate the effects of an enemy's countermeasures that interrupt radio communications. How effective these methods are depends on the operator and his equipment.

Preventive Measures

General preventive measures used for ECCM planning include ADA sensor section equipment setting, use of directional antennas, minimum transmitting power, traffic control, reporting schedules, proper use of transmitter, and security. Descriptions of these preventive measures are in FM 24-33.

Jamming and Operator Training

The most important factor in defense against electronic countermeasures (ECM) is well-trained radio operators. Training should be so thorough that radio operators expect jamming. Inadequate antijamming training may result in surprise, confusion, and panic within the section during an enemy attack. Even if deliberate jamming is never encountered, training is valuable because man-made or natural interference of one kind or another is certain to be encountered during communications. Training to work through jamming is an effective tool for the ADA sensor section. Additional measures to employ when training operators to work through jamming are in FM 24-33.

ADA DECISION SUPPORT MATRIX

	DP1	DP2	DP3	DP4
EVENT	HIP AND HIND ATTACKING NORTHERN FLANK WHILE MOVING ALONG AXIS BLUE	HIP AND HIND ATTACKING SOUTHERN FLANK WHILE MOVING ALONG AXIS BLUE	HIP AND HIND ATTACKING NORTHERN FLANK WHILE IN THE ASSAULT	HIP AND HIND ATTACKING SOUTHERN FLANK WHILE IN THE ASSAULT
EW	OBSERVE NAI 1	OBSERVE NAIS 2 AND 3	OBSERVE NAI 4	OBSERVE NAI 5
1/B	REINFORCE 3/B N, NE	REINFORCE 3/B S, SE	REINFORCE 3/B N	REINFORCE 3/B S
1/4/B	MOVE WITH LEAD ELEMENTS OF TF 3-77 N, NE	MOVE WITH LEAD ELEMENTS OF TF 3-77 S, SE	MOVE WITH LEAD ELEMENTS OF TF 3-77 N, NE	MOVE WITH LEAD ELEMENTS OF TF 3-77 S, SE
2/B 2/4/B	MOVE UP TO JOIN LEAD ELEMENTS OF TF 3-80 N, NE	MOVE UP TO JOIN LEAD ELEMENTS OF TF 3-80 S, SE	MOVE TO OVERWATCH POSITIONS N	MOVE TO OVERWATCH POSITIONS S
3/B 4/4/B	MOVE UP TO JOIN LEAD ELEMENTS OF TF 3-2 N, NE	MOVE UP TO JOIN LEAD ELEMENTS OF TF 3-2 S, SE	MOVE TO OVERWATCH POSITIONS N	MOVE TO OVERWATCH POSITIONS S
3/4/B	BSA PTLs	BSA PTLs	BSA PTLs	BSA PTLs
C²	BDE TAC	BDE TAC	BDE TAC	BDE TAC
CSS	BSA	BSA	BSA	BSA
CAAD	ORIENT NORTH	ORIENT SOUTH	ORIENT NORTH TAI 2	ORIENT SOUTH TAI 1

Figure 2-1

CHAPTER 3

Section Employment

This chapter discusses the function of ADA sensor platoon personnel during movement. Movement includes selection of the site on which the section will be positioned, preparation of the site and establishing communications, and local security. Movement is frequently done to support the sensor plan, because of a change in mission, or for survivability.

MOVEMENT ACTIONS

The ADA sensor platoon leader and section chiefs must remain informed of current and anticipated operations in preparing for a movement. Position area, route, and critical time information is generated by the mission of the supported unit and the battery commander when in a DS role or the battalion S3 when in a GS role. Movement activities fall into the following sequence:

1. Receive the movement warning order.
2. Make a map reconnaissance.
3. Plan the movement.
4. Deploy, occupy, and improve the position.

The following paragraphs discuss actions dealing primarily with the ADA sensor section activities.

RECEIVE THE MOVEMENT WARNING ORDER

The movement warning order to the ADA sensor section is issued by the ADA sensor platoon leader or ADA battalion S3. The movement warning order is normally verbal. It may be passed in person or over tactical communications equipment. The warning order must include the following:

- The new mission.
- The coordinates of the new positions.
- Time of release for march order, crossing the start point (SP), and assuming operational status at the new position.
- Authentication, if passed by radio.

MAKE A MAP RECONNAISSANCE

It is the responsibility of the sensor platoon leader and section chiefs to analyze the terrain over which they must travel and transmit radio traffic. If time permits, creating a banded relief map of the area of operations assists in performing this task. This function will show possible observation points, steering

points for navigation, and if and where FM retransmission sites are required. It will show areas of radar masking and where aircraft may use nap-of-the-earth (NOE) flight. The relief map also will indicate the slope of the terrain, and possible hiding places for vehicles will be observation and listening posts (OPs and LPs). Refer to the Banded-Relief Overlay illustration on page 3-2, for an example. Map reconnaissance includes--

- Ensuring that the route and location of the ADA sensor section meet tactical and technical requirements.
- Identifying possible ambush locations.
- Avoiding built-up areas, when possible.
- Identifying access and exit routes.
- Noting vegetation and drainage.
- Finding march routes, start points (SPs), release points (RPs), and checkpoints.
- Identifying areas of masking where FM radio will not have line of sight.
- Identifying and marking passage points, linkup points, and lanes for traversing friendly minefields. If aerial photographs are available for your area of operations, use them and report any changes to higher headquarters. Plan your work and work your plan.

PLAN THE MOVEMENT

The ADA sensor section must plan for movement. These plans should include the following:

- The time the ADA sensor section must be in operation at the new site.
- Routes, primary and alternate, for movement to selected area.
- Travel time from the old site to the new site.
- Communications during the displacement.
- Convoy procedures and site security during the move and occupation. Anything on the modern battlefield that moves can be detected. The night offers maximum concealment, so the ADA sensor section should generally move at night. The platoon leader or the section chief must balance these factors when determining the type of movement to use. See the Movement Techniques illustration.

[Figure 3-1.](#)

[Figure 3-2.](#)

The listening aspect of intelligence gathering must not be overlooked. It indicates activity to either avoid or investigate. While moving in a vehicle, it is a good idea periodically to turn off the vehicle engine and listen for short intervals. Refer to Appendix B for information on listening techniques. Record the conditions and types of bridges, tunnels, roads, and warning signs encountered during movement to the position. Units on the offensive may need to take or avoid your route due to the size and weight of their weapon systems and support vehicles. Once the plan is formed, orders are issued. The extent of preparation a section can make before movement depends on time, personnel, equipment, and material availability. Preparations should include marking the site for each adjacent ADA sensor section and supporting ADA fire unit on the section chief's map.

DEPLOY

Before travel, the ADA sensor section members ensure that all preparations for travel are completed. Because of the inherent mobility of the supported forces, ADA sensor sections could travel less than 30 to 50 kilometers for a short march or over 50 kilometers for a sustained march. The distance traveled would be according to the TSOP.

SELECT POSITION

ADA sensor sections should be positioned to effectively observe the NAI. The section should be within 100 meters of their primary position. Otherwise, surveillance coverage may be degraded. ADA sensor section personnel should look for positions that offer the following:

- Good access and exit routes to and from the position.
- Cover and concealment available to enhance survivability.
- Maximum surveillance coverage of assigned search sectors.
- Overlapping surveillance coverage.
- Immediate occupancy.
- Defensibility against ground attack.
- Excellent lines of communications.

The ADA sensor section must be positioned to have line of sight (LOS) along the expected air avenues of approach and the designated NAI. A view of 15 kilometers is desirable. The section chief also must consider factors affecting communications when selecting a site. The mission of the ADA sensor section is not only to detect aircraft, but more importantly, to broadcast alerting and EW information. If EW or radio contact with higher, lower, and supported unit cannot be achieved, the site should not be considered for selection.

PRIMARY AND ALTERNATE POSITIONS

In selecting positions for the section, the ADA sensor section chief must consider movement to other positions for survivability. The ADA sensor section's ability to accomplish rapid emplacement and march order enhances its survivability. The primary position should be the best position available for the ADA sensor section to accomplish the tactical mission. The alternate position should meet the requirements of the primary position. It is used when the primary position becomes indefensible or unsuitable for accomplishing the tactical mission. Although this position is generally close to the primary position (200 to 500 meters), it should not be so near that it is also subjected to the same conditions that rendered the primary position indefensible or unsuitable.

BANDED-RELIEF OVERLAY

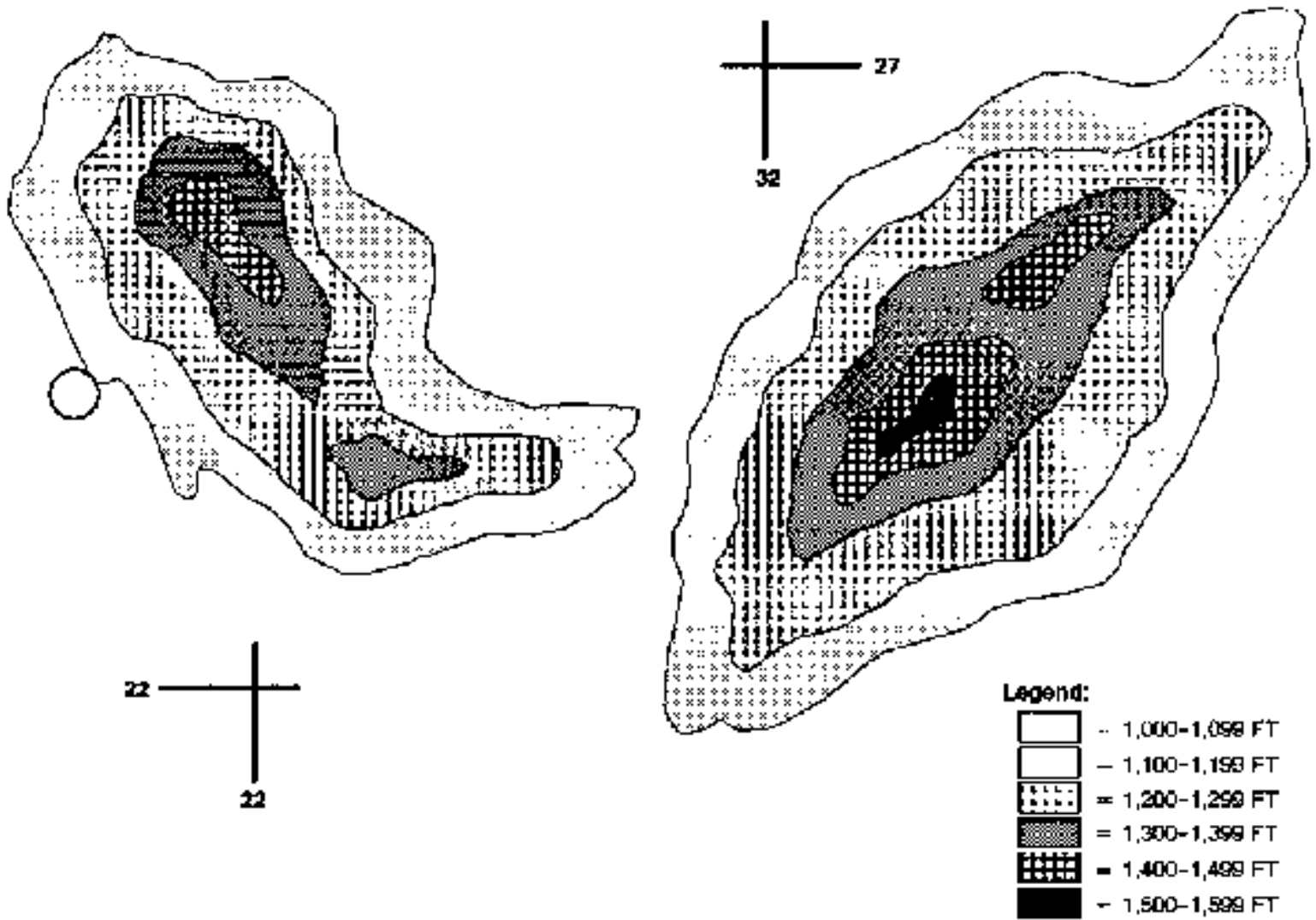

Figure 3-1

MOVEMENT TECHNIQUES

MODE	PLANNING	DETECTION	COMMENTS
Foot March	Extensive planning regarding routes; the load carried is minimal.	Minimal even in high-light conditions.	Time-consuming, fatigue; land navigation and terrain are factors.
HMMWV	Extensive, may be stopped by open ground; restrictive terrain loads are not problems.	By radar, noise, and high-light conditions.	Less time-consuming than foot march; land navigation and terrain are factors.
Heliborne	Assets must be available; prior planning is difficult; some weight limitations may apply.	Minimal by ground radars; noise could be a problem.	Fast; land navigation is minimized; fatigue is not a factor.

CHAPTER 4

Sensor Section Emplacement, Survivability, and Operations

This chapter describes the tactics, techniques, and procedures (TTP) for emplacement of the ADA sensor section. TTP will help the section maximize their capabilities while performing their mission.

SURVIVABILITY

The ADA sensor section, as with any air surveillance asset, presents lucrative targets for enemy ground and air attack. Though the section is highly mobile, it should be employed in unsecured areas only when dictated by mission requirements or METT-T. ADA sensor section site selection should be made without degrading its mission. Section survivability against enemy air and ground attack can often be improved by the following areas.

BATTLEFIELD SURVIVAL

Actions that should be taken to improve battlefield survival include the following:

- Selecting a position that is hidden from enemy ground observation (for example, the military crest of a hill).
- Moving using stealth.
- Moving into positions during darkness.
- Taking advantage of terrain to provide natural cover and concealment for the ADA sensor section and its organic vehicle.
- Using camouflage netting and natural materials to camouflage and conceal the position.
- Blending equipment into natural background.
- Erasing and covering tracks when vehicle is mounted.
- Keeping position litter-free.
- Enforcing noise and light discipline.
- Collocating with task force/brigade.

MOBILITY

One way to keep the enemy confused about the location of the ADA sensor section is to conduct survivability moves. Because of their light configuration, mobility is one of the key assets of the ADA

sensor section. Although the sensor section will normally be deployed in HMMWV with mounted radios, the tactical situation may dictate that the sections deploy on foot. Though they are capable of rapid emplacement and march order, the distances moved may vary. The movement distance must depend on METT-T and the tactical situation. The movement should be as rapid as possible to get back into operation providing early warning. Things to consider regarding movement are as follows:

- Move as required to keep the enemy from targeting the position (such as, survivability move of 200 to 500 meters).
- Move at night if possible or when visibility is limited.
- Move quickly--get back into operation.
- Move after recent air or ground reconnaissance of the area.
- Move if the position has been fired upon. Alternate positions must be identified and are normally briefed in the operation order.

FORTIFY POSITIONS

Although mobility is fundamental to the ADA sensor section, the tactical situation could dictate that the section fortify its position. This is especially true when the section is unable to take advantage of natural cover and concealment. Use of field fortifications reduces damage to equipment and injury to members when enemy forces

locate and attack an ADA sensor section site. Two restrictions make it difficult for the ADA sensor section to construct adequate fortifications. One is the limited number of personnel to do the work. The other is the time the section has to fortify the position. However, the section should attempt to fortify the position to the best extent possible. The use of available concertina wire and claymore mines will provide additional position security. As a minimum, every section member should plan to have an individual prone shelter. The section chief determines if fortification should be initiated. Positions should be improved throughout the section's occupation. The ADA sensor section chief should choose positions that cannot be seen by enemy ground observation posts. Look for areas that provide natural protection, such as mounds or depressions. They can easily be enhanced with sandbags or other materials. The section should obtain dirt and other natural materials at a distance from the position to avoid disturbing the immediate area.

OCCUPY, EMPLACE, AND IMPROVE POSITION

Upon arriving at the position selected during the map reconnaissance, the section's primary goal is to become operational and provide early warning for the force. The distribution of tasks and teamwork make the process of reaching the primary goal easier and quicker. This means that as members of a section, the section chief, sensor section operator, and section driver/operator must perform their individual tasks quickly and efficiently. The following priority phases for the ADA sensor section should be established for emplacement. Although some of them are accomplished simultaneously, each must be completed.

ESTABLISH LOCAL SECURITY

Establish local security and defense against ground attack by infiltrators or guerrillas. Section personnel

sweep the area and establish guard posts with communications for quick reaction.

EMPLACE THE ADA SENSOR SECTIONS

When the section arrives at the selected position, the driver maneuvers the vehicle into a position that provides the best natural cover and concealment and allows for coverage of the assigned NAIs. The sensor section member selects a tactical remote position that ensures an adequate field of vision and good cover and concealment. Look for areas to emplace the HMMWV and OP/LP on the military crest of a hill, not on the top.

ESTABLISH COMMUNICATIONS

Establish communications and enforce security procedures at all times. The ADA sensor section establishes all required radio communications, and when the tactical situation indicates, begins to transmit over the DEW broadcast net.

IMPROVE POSITIONS

Improve ADA sensor section positions as soon as time and tactical situation permit. Erase tracks made by the section and vehicle. Camouflage personnel and equipment using natural material, where possible. Supplement natural camouflage by using artificial material. Hide positions should be established for immediate use. The section chief should complete an ADA sensor coverage diagram that reflects ranges to critical points on all likely avenues of approach (see the Sensor Section Coverage Diagram).

PREPARE ALTERNATE POSITION

As time allows, select and prepare an alternate position. This will enable the ADA sensor section to move to it quickly whenever the primary position is compromised.

NBC OPERATIONS

Both en route to and while in its tactical position, the ADA sensor section could be subjected to an NBC attack. The section will be at mission-oriented protection posture (MOPP) level designated by the commander. In the event of a chemical or biological attack, the section's first action should be self-protection. The section will immediately go to MOPP 4. Upon attack, NBC 1 observer's report is sent to higher headquarters. Other section members use chemical detection kits to detect chemical agents. If the kit indicates that the area is contaminated, turn off all power and disconnect the power cable from the generator or other power source. Once the NBC 1 report has been sent, decontamination procedures should start. Rinse all exposed surfaces with water, allow to dry, and retest. If you use such decontaminates as DS2, follow the directions to prevent damage to the equipment.

[Figure 4-1.](#)

NIGHT AND ADVERSE WEATHER OPERATIONS

While at their location, the ADA sensor section can operate at night and during adverse weather conditions. The procedures for communications of early warning data are the same as in daylight. Communications requirements remain the same.

SENSOR SECTION COVERAGE DIAGRAM

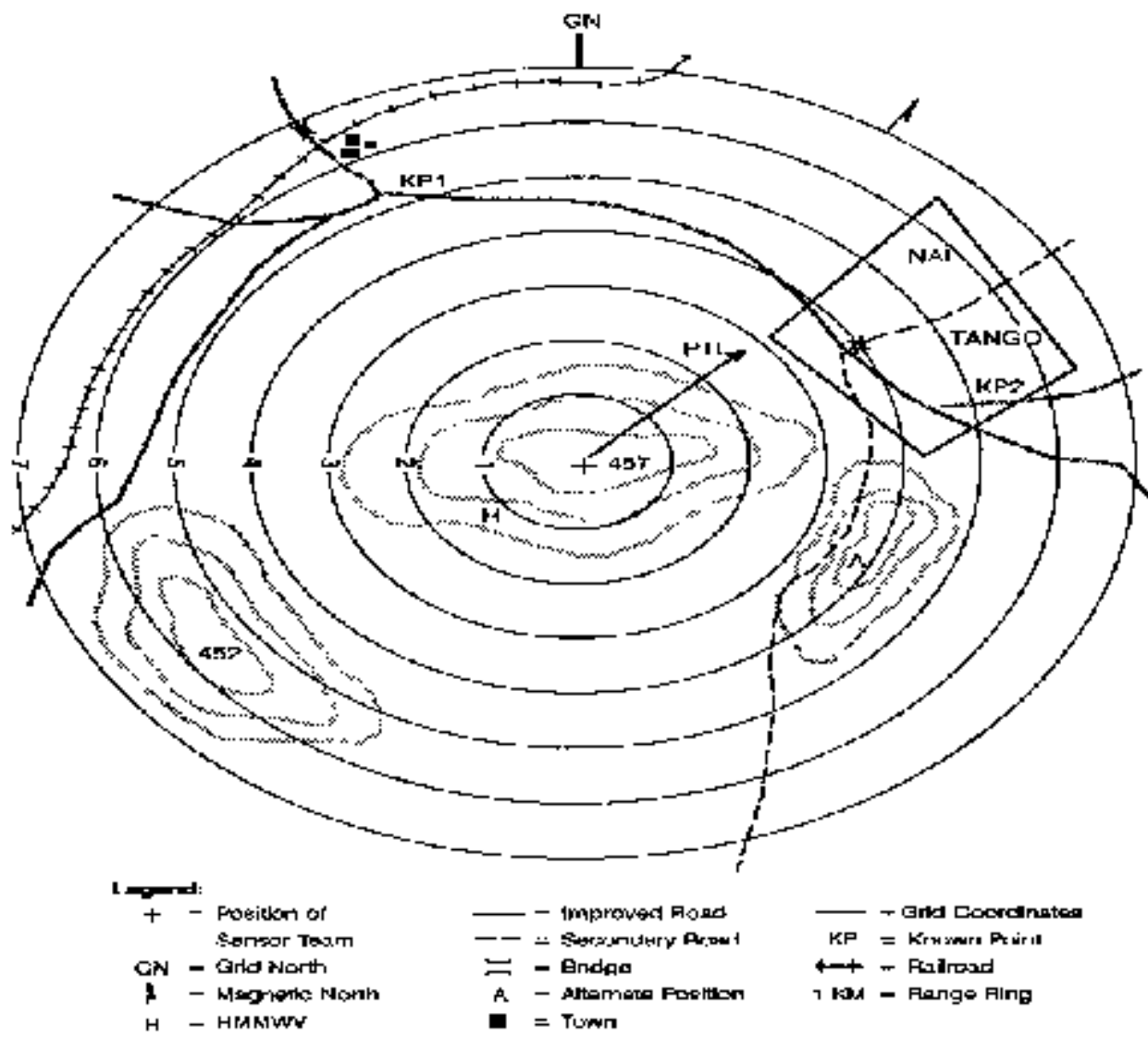

Figure 4-1

CHAPTER 5

Identification and Reporting

This chapter describes how identification and reporting are done in the ADA sensor platoon and section. The identification and reporting of enemy activities is extremely important to the gathering of information and intelligence. These actions are accomplished in various ways.

VISUAL AIRCRAFT RECOGNITION

In the absence of radar and identification, friend or foe (IFF) devices, the ADA sensor section must be proficient in visual aircraft recognition (VACR) skills. VACR skills are outlined in FM 44-80 and the ground observer aircraft recognition (GOAR) kit. Other aids in VACR include graphic training aids (GTAs), such as GTAs 44-2-5, 44-2-6, 44-2-7, and 44-2-8. Additional sources include current slide photos and updated GTAs as provided by the training and audiovisual support center (TASC) office for your organization. The ADA battalion S2 maintains files for aircraft used in specific regions of the world. These files and training aids will help focus the training effort of the ADA sensor sections prior to deployment. Each ADA unit is responsible for conducting VACR training to standard. The ADA sensor section member must observe and report the types and number of aircraft found in the NAI he is assigned. This includes both friendly and enemy aircraft. His reports must be accurate so ADA fire units do not engage friendly aircraft. He must not only report the number and type of aircraft, but also the actions taken by the aircraft. For example, the sensor section will report, "Dynamite, Dynamite, three, vicinity TANGO Two (NAI), heading east, strafing and smoke" to describe three enemy aircraft at NAI TANGO Two.

HOSTILE CRITERIA

Hostile criteria are those conditions under which an aircraft or vehicle may be identified as hostile for purposes of engagement. Hostile criteria consist of, but are not limited to, the following:

- Aircraft attacking friendly elements (strafing, bombing, or firing rockets).
- Aircraft discharging smoke or spray.
- Aircraft discharging parachutists in excess of the normal crew.
- Aircraft engaging in mine-laying operations.
- Aircraft making unauthorized entry into restricted areas.
- Aircraft operating at prohibited speed, altitude, or direction.
- Aircraft bearing military markings or configurations of known enemies.
- Aircraft replying with improper IFF response (possible hostile).

Note: Discharging flares is not a hostile act.

ATTACK PROFILES

The following illustrations show known profiles for fixed- and rotary-wing formations and delivery methods for conventional and smart munitions. These illustrations help the sensor section member determine the action that an aircraft is conducting.

[Figure 5-1.](#)

[Figure 5-2.](#)

[Figure 5-3.](#)

[Figure 5-4.](#)

[Figure 5-5.](#)

[Figure 5-6.](#)

[Figure 5-7.](#)

[Figure 5-8.](#)

REPORTING

The ADA sensor section acts as the eyes and ears of the ADA S2, leaders, and fire units. The ADA sensor section has the responsibility of reporting items out of the ordinary on the ground and in the air. When reporting on troop or vehicular movements, use the standard SALUTE report. When reporting unknown aircraft, use the WEFT methods and fin flash descriptions. If new ordnance is sighted, try to provide as much detail as possible without exaggeration. Such items as the size and depth of the crater are helpful, as well as the type of launcher or platform used. Under the fully automated FAAD C3I system, tracks will be automatically sent to the A2C2 and ABMOC from the AWACS. That information is then sent to the sensor C2 nodes who in turn send it out to their customers, that is, ADA batteries in support of their respective maneuver brigades. When resorting to manual EW using MSCS, the ABMOC receives EW information from the sensor sections and the nearest HIMAD source; they correlate it then send it to the respective ADA batteries in support of the maneuver brigades. This information is broadcasted over the DEW net and command nets. The communications used are the AM and FM radios. The AM is the ADA sensor net; it is used to send EW, NAI, TAI, and AAA information to the ABMOC. The FM is the command net. This net can also be used to send directed early warning according to the established SOP and METT-T.

POP-UP TECHNIQUE

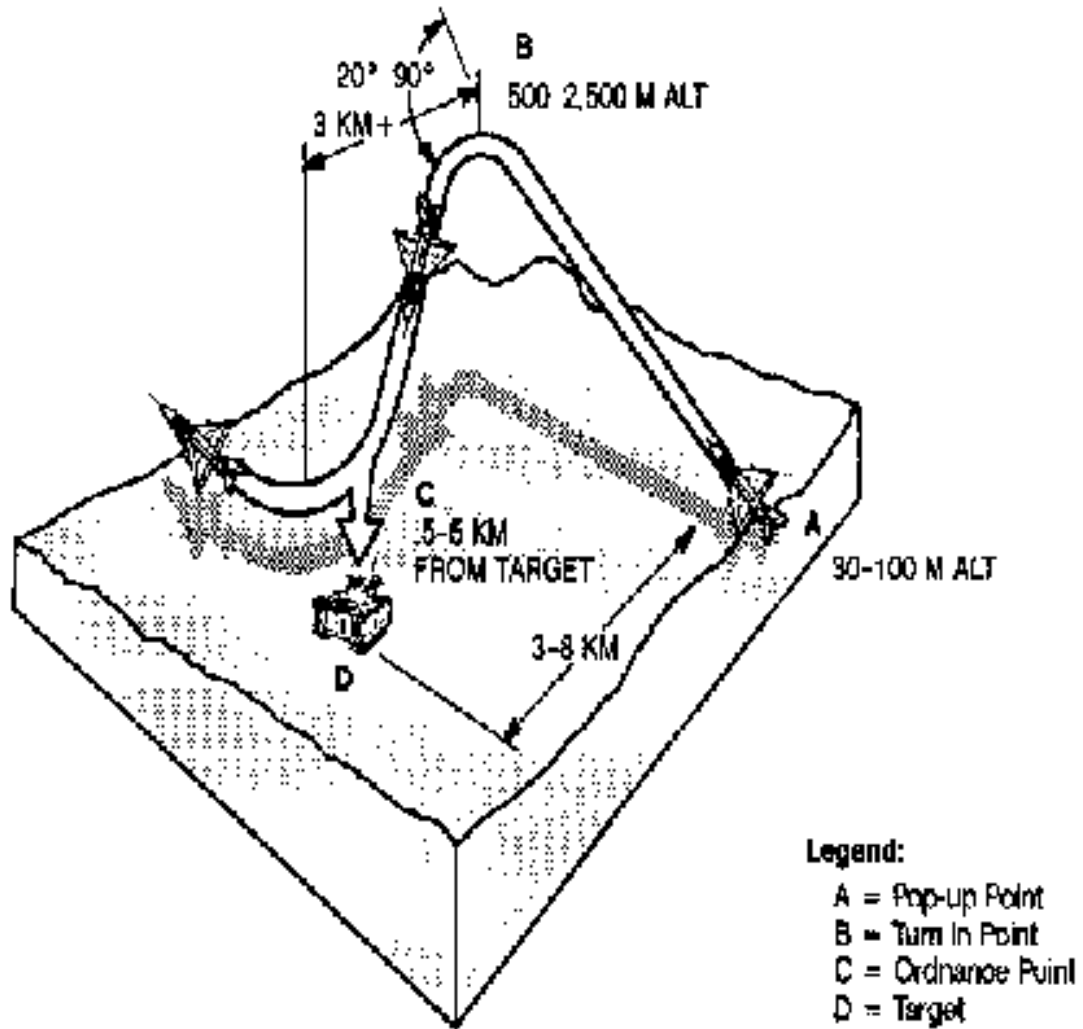

Figure 5-1

LAY-DOWN TECHNIQUE

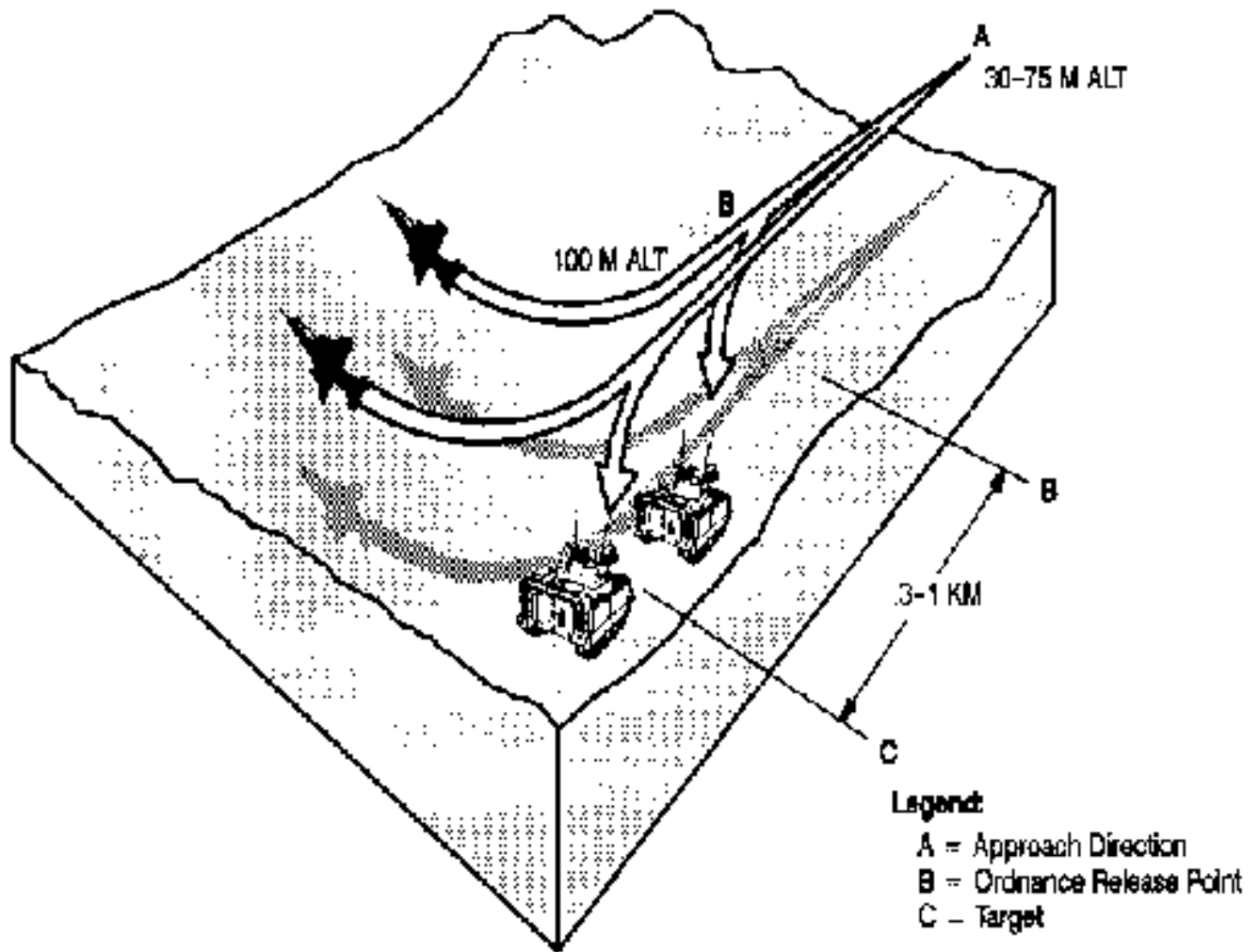

Figure 5-2

POP-UP/LAY-DOWN TECHNIQUE

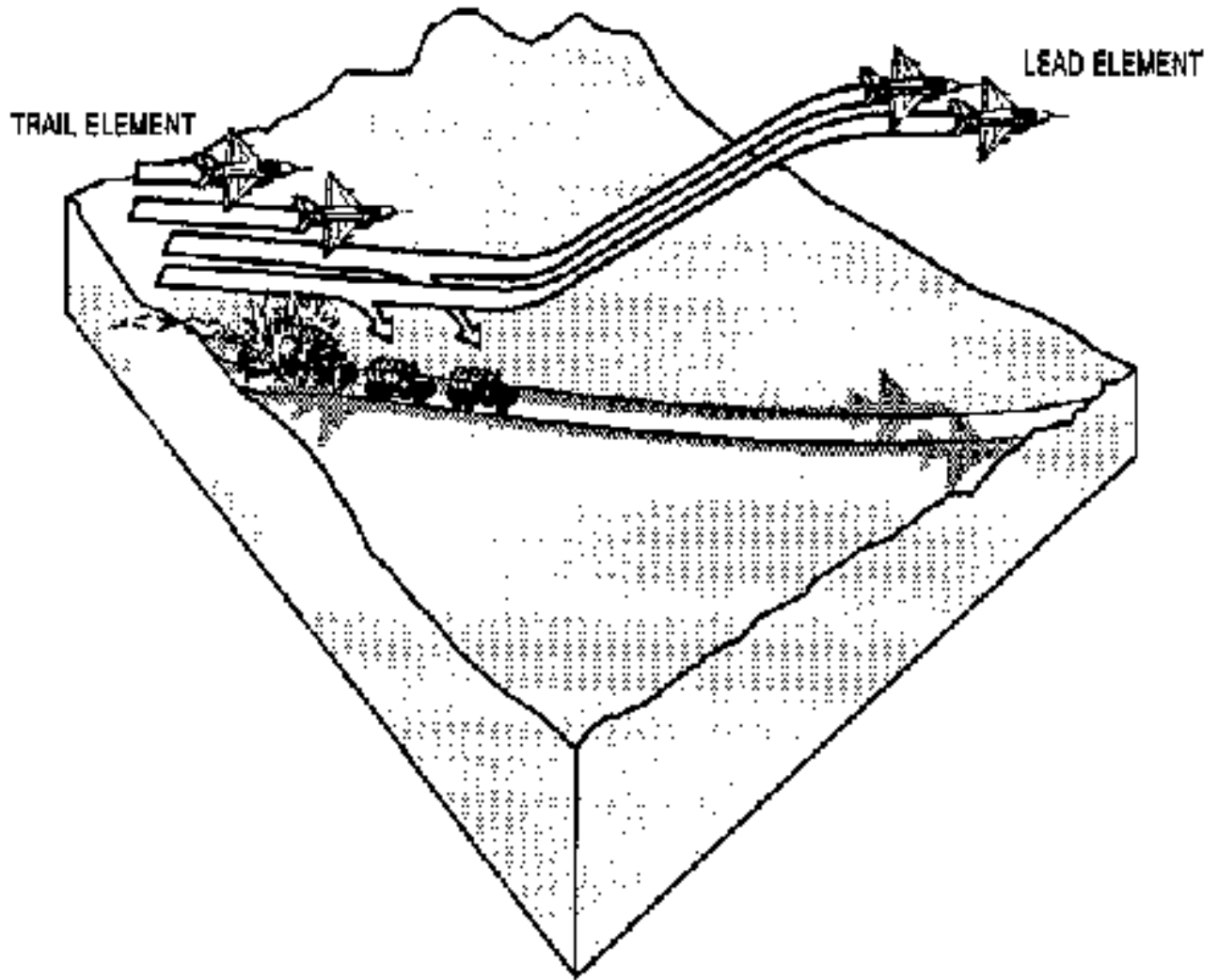

Figure 5-3

TV COMMAND

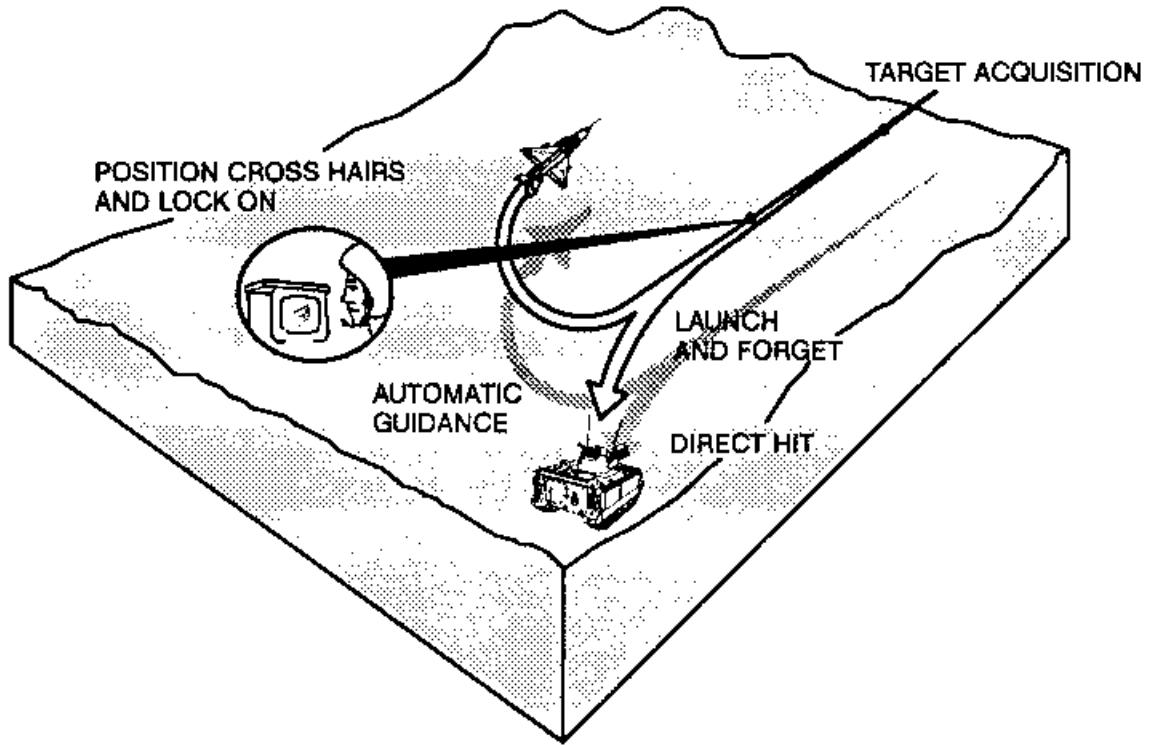

Figure 5-4

TV COMMAND

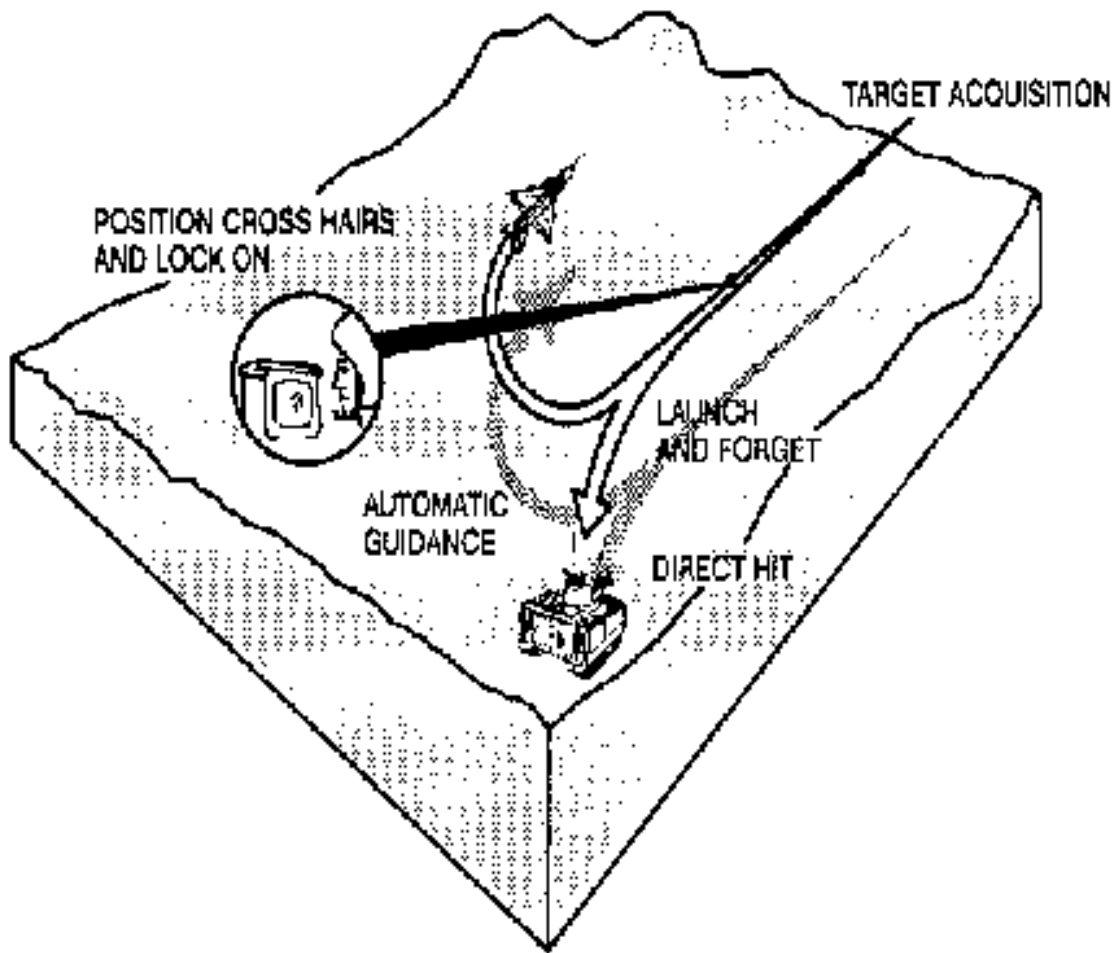
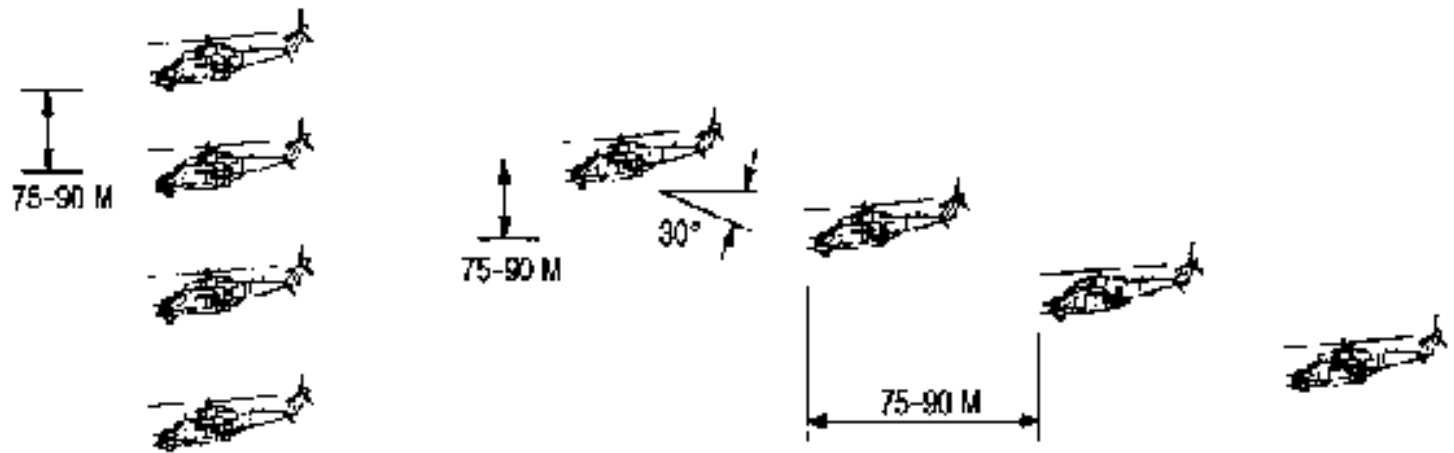

Figure 5-5

OPPOSING FORCES FORMATION



Line-

- Distances between aircraft: 75-90 M.
- Aircraft line up vertically

Echelon (right or left)-

- Distances between aircraft: 75-90 M.
- There is a 30-degree angle between aircraft.

Note: Not drawn to scale.

WELDED-WING CONCEPT

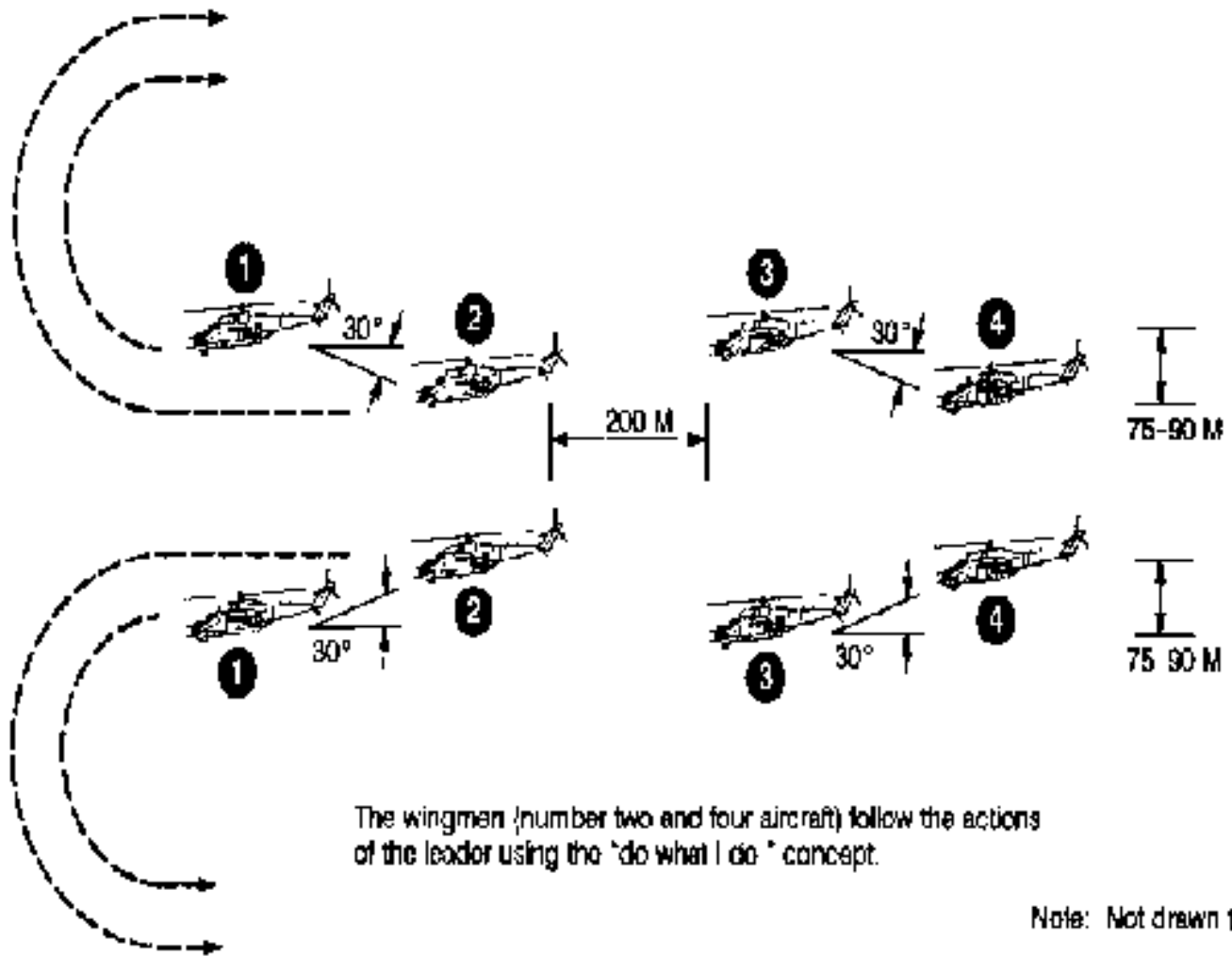

Figure 5-8

APPENDIX A

Responsibilities

The ADA sensor platoon provides early warning and alerting information to the maneuver force through the ABMOC/BNTOC. To achieve this, the platoon leader and section members must be highly trained in the accomplishment of all their respective duties. They must have a clear understanding of the capabilities and limitations of their personnel and equipment to fully exploit the sensor section's capabilities.

AIR DEFENSE COORDINATOR

The ADCOORD coordinates the EW coverage of HIMAD weapon systems. Also, he is responsible for deconflicting terrain problems for sensor sections. He ensures that corps or division airspace management element cells know the locations of the sections. He is responsible for providing the corps or division G2 with the ADA sensor sections' PIRs.

BRIGADE OR TASK FORCE S3

The brigade or task force S3 is responsible for incorporating the sensor sections into the scheme of maneuver, when applicable. He assists in the coordination of terrain management for the sections and plots the location of the sections on the brigade operations map. He processes the EW information provided by the sections for dissemination to maneuver forces.

ADA BATTALION S3

The ADA S3 is responsible for planning the air defense coverage of the maneuver force, and developing the DST and DSM, and in conjunction with the ADA S2, developing the R&S plan. He coordinates the terrain management of sensor sections' positions, and plots their locations on the battalion operations; overlay. He coordinates the sensor section movement and keeps the ADCOORD informed of the movement. Additionally, he incorporates the sensor sections into the ADA scheme of maneuver. The ADA battalion S3 disseminates the rules of engagement for ADA assets and ensures that they are understood by all ADA soldiers. He will establish and maintain communications with the sensor platoon. He processes all information that is provided by the ADA sensor sections.

ADA BATTALION S2

The S2 is responsible for the air and ground IPB. He will develop the air order of battle and assist the commander in the development of PIRs. He templates possible enemy FARPs and LZs and identifies

NAIs and TAIs. He will integrate the sensor platoon into the brigade or TF R&S plan and works with the S3 to develop the ADA battalion R&S plan in consultation with the battalion commander and sensor platoon leader. The primary purpose of the R&S plan is to answer the commander's PIRs. In addition, the S2 processes the information provided by the sensor sections and updates his IPB, as appropriate.

Based upon the intelligence and early warning requirements, the S2 should accomplish the following actions in developing the collection plan:

- Break down PIR and information requirement into specific indicators on which R&S assets can collect. Each asset should be told exactly what to look for (such as, activation of enemy air defense radars, launching of fixed-wing aircraft, et cetera).
- Associate specific NAI to each indicator.
- Locate grid coordinates or designate points for each NAI.
- Determine the time (not earlier than and not later than) or trigger point for activation or surveillance for collection assets.
- Provide specific orders to each collection asset (such as, reporting format and what to report).
- Maintain a list of available collection agencies (organic, adjacent, and higher) on the collection plan (such as HIMAD, sensor sections, batteries, joint surveillance target attack radar system (JSTARS), liaison elements, maneuver scouts, and other intelligence assets).
- Develop an R&S overlay, matrix, or other appropriate tool to ensure integration of organic and external assets and to preclude gaps in coverage.
- Ensure that appropriate control measures are included in maneuver unit plans to protect sensor sections and prevent fratricide by friendly units.

PLATOON LEADER

The sensor platoon leader employs his forces in coordination with the S2 and S3 to best collect information on assigned NAIs. He is responsible for the discipline and training of his platoon. He is responsible for developing his soldiers into an effective fighting force capable of performing its combat mission. Additionally, he is responsible for aiding the S2 in the development of the ADA R&S plan. The platoon leader works closely, and coordinates, with the ADA battalion S2 and S3 to develop and implement the R&S plan. He must coordinate the terrain management plan for the positions of his sections. Once the battalion commander has approved the R&S plan, the platoon leader is responsible for establishing and maintaining communications links to the ADA battalion and the sensor sections. He positions his sections per the R&S plan. The platoon leader locates on the battlefield where he can best control his assets.

PLATOON SERGEANT

The platoon sergeant is second in command of the platoon. He must be proficient in all of the tasks normally accomplished by the platoon leader. He must be prepared to assume the responsibilities of the platoon leader at a moment's notice. He must ensure that section members are trained to perform their duties for their combat mission. The platoon sergeant is responsible to the platoon leader for the maintenance, logistics, and discipline of the platoon. He is responsible for the coordination of all logistical and maintenance support the platoon requires. The platoon sergeant must work in close

coordination with the platoon leader to ensure unity of effort.

SECTION CHIEF

The section chief is responsible to the platoon leader and platoon sergeant for the training, discipline, and tactical employment of his sensor sections. Although the platoon leader designates the area for positioning the sensor sections according to the guidance from the S2 and S3, the section chief is responsible for the selection of the specific site where the section will emplace. He coordinates with the platoon sergeant for resupply and maintenance support of his sections. He is responsible for the maintenance of all assigned equipment. He submits all tactical and logistical reports. He is responsible for the reporting of PIRs, NAIs, TAIs, and AAAs, and providing EW to the ABMOC who in turn will send that information to the ADA batteries and their respective maneuver brigades.

APPENDIX B

Observation Techniques

This appendix is an overview of observation techniques and equipment. The last part of this appendix deals with tactical uses of night vision devices (NVDs) and training tips. Although the prime reference is night operations, the material also applies to limited visibility operations (fog, rain, snow, and sandstorms).

OBSERVATION--DAYLIGHT TECHNIQUES

An observer's capability to detect aircraft increases as the size of the search sector assigned decreases. Detection is more likely if an observer is assigned responsibility for searching a narrow sector than if he is responsible for searching the entire area surrounding his position. If an alert warning system is supporting the observer, he may be assigned a fairly large sector (for example, 90 degrees) for general surveillance. When a warning is received, he then narrows his search sector (for example, to 30 degrees) and centers it on the aircraft's approach azimuth. Decreasing the sector size to less than 30 degrees is not advisable because the alert warning system azimuth data may not be accurate. An error of only a few degrees may cause the observer to miss an aircraft. Often observers, using the horizon as a reference, tend to concentrate their search near the horizon and disregard objects high above the horizon. Therefore, when assigning search sectors, the sector should be defined in both horizontal and vertical planes (see the illustration below).

Figure B-1.

A simple way to estimate how high above the horizon to search is to use the hand. Facing the primary target line (PTL), extend either the left or right arm fully and extend the fingers. The tips of the thumb and little finger should form a line perpendicular to the ground. Now, when the little finger is touching the horizon, the tip of the thumb is approximately 20 degrees above the horizon (see the illustration below). The observer should frequently focus his eyes on a distant object, such as a cloud or terrain feature (otherwise, the eyes tend to relax and distant objects become blurred). Search the area near the sun by extending arm and hand to block out the sun's glare. Looking into the sun without shielding the eyes will cause them to become blinded for a few seconds. This may cause the observer to lose sight of the target. The observer should squint his eyes if he has trouble focusing at long ranges. Squinting compresses the eyeballs, thus changing their focal length and making distant objects come into focus. The observer should keep his eyes on the aircraft once he sees it. If he has to look away from it, he notes the direction of the aircraft and moves his eyes away from it when the aircraft is near some object, such as a cloud or a terrain feature, that will guide his eyes back to it. Observers may use one of two systematic methods of search to look for aircraft in any type of terrain. In the first method, the observer searches the horizon to about 20 degrees (356 mils) above the horizon by moving his eyes in short

movements across the sky, working his way up and across. He continues the scan pattern to below the horizon to detect aircraft flying nap-of-the-earth (see the Horizontal Scanning illustration). In the second method, the observer searches the sky using the horizon as a starting point and prominent terrain features as points of reference. He moves his eyes in short movements up the sky, then back down, continuing this movement across the terrain. He scans in the same pattern below the horizon to detect aircraft flying NOE (see the Vertical Scanning illustration). Observers with more experience and above average visual acuity may use nonsystematic methods of search that work best for themselves such as--

- Combination of the two systematic methods.
- Search of the horizon in the shape of an oval to about 20 degrees above the horizon.
- General and random search of the horizon.

When the sensor section occupies a tactical position, each section member will take turns searching for aerial targets. This allows one member to search while his partner rests his eyes and provides ground security. Search sectors are arranged to provide all-around coverage of the entire area and overlapping coverage of the assigned sector of search on likely approach routes. When aircraft are detected, section members shift primary search emphasis to the azimuth of approach (with frequent all-around scans) and send the appropriate reports. At times, the sensor section will be assigned a sector of responsibility by the sensor section chief or the supported unit commander.

[Figure B-2.](#)

[Figure B-3.](#)

[Figure B-4.](#)

WHERE TO SEARCH

A map reconnaissance of the supported unit's direction of movement or area of operation will help to pinpoint areas from which aircraft are most likely to attack the unit. Mark the far sides of wood lines, ridge lines, and significant folds in the terrain out to at least 3,000 to 5,000 meters. This is where attack helicopters can lie in wait at the maximum range of their antitank guided missiles (ATGMs). Mark restricting terrain, defiles, and narrow valleys where the maneuver unit may be forced to pinch together, becoming lucrative targets for air attack.

TELL-TALE SIGNATURES

Many aircraft have tell-tale signatures which can lead to early detection. Sensor sections should look for the following:

- Sun reflection from aircraft canopies or cockpit windows.
- Blade flash from rotating helicopter blades.
- Smoke or vapor trails from jet aircraft and missiles or rockets fired from aircraft.
- Dust or excessive movement of tree tips and bushes in a particular area.
- Noise from helicopter blades or from jets breaking the sound barrier.

OBSERVATION--NIGHT AND LOW-LIGHT TECHNIQUES

Observation at night and in low-light conditions differs greatly from the observation techniques used during daylight hours. The following paragraphs discuss the impact of night and low-light conditions on the ADA sensor section.

DARKNESS INCREASES THE SOLDIER'S SENSE OF FEAR

The ADA sensor section's isolation may lead to a feeling of impending peril. The section member imagines dangers and may panic under sudden stress. He has a tendency to doubt the unknown. The unseen enemy increases his fear at night. Isolation reduces combat efficiency. During night or limited visibility conditions, isolation is intensified. Even small distances between individuals are exaggerated at night. The ability to function and fight at night is directly related to individual skills, unit teamwork, and confidence in leaders. Confidence is built through practice and unit cohesiveness. Skill, will, and teamwork develop sections which can operate effectively at night.

PHYSICAL FACTORS OF NIGHT OPERATIONS

Just as the night affects the mind, it also affects the senses of sight, hearing, and smell. Maximizing the capabilities of the senses enhances the ability to fight at night. Improving the senses of hearing and smelling requires training; vision is maximized by understanding how the eye operates at night and how to efficiently use its capabilities.

Night Vision

The eye's vision at night is different from daytime vision. At night, it sees with spiral eye cells called rods. Rods cannot differentiate color and are easily blinded when exposed to light. This creates a central blind spot which causes larger and larger objects to be missed as distances increase (see the Central Vision--Night Blind Spot illustration).

Protecting Night Vision

While working and performing tasks in daylight, the exposure to light directly affects night vision, and repeated exposure to bright sunlight has an increasingly adverse effect on dark adaptation. Exposure to intense sunlight for two to five hours causes a definite decrease in visual sensitivity which can persist for as long as five hours. This effect can be intensified by reflective surfaces such as sand and snow. At the same time, the rate of dark adaptation and degree of night vision capability will be decreased. Since these effects are cumulative and may persist for several days, military neutral density (N-15) sunglasses or equivalent filter lenses should be used in bright sunlight when night operations are anticipated.

Night Vision Scanning

Dark adaptation or "night vision" is only the first step toward maximizing the ability to see at night. Night vision scanning can enable soldiers to overcome many of the physiological limitations of their eyes and can reduce the visual illusions that so often confuse the observers. The technique involves scanning from right to left or left to right using a slow, regular scanning movement (see the Typical Scanning Patterns illustration). Although both day and night searches employ scanning movements, at night it is essential to avoid looking directly at a faintly visible object when trying to confirm its presence.

[Figure B-5.](#)

[Figure B-6.](#)

Use of Off-Center Vision

Viewing an object using central vision during daylight poses no limitation, but this technique is ineffective at night. This is due to the night blind spot that exists during periods of low illumination. To compensate for this limitation, soldiers are taught to use off-center vision. This technique requires that an object is viewed by looking 10 degrees above, below, or to either side of it, rather than directly at the object. This allows the peripheral vision to maintain contact with an object (see the following illustration).

[Figure B-7.](#)

Countering the Bleach-Out Effect

Even when off-center viewing is practiced, the image of an object viewed longer than two to three seconds tends to bleach out and become one solid tone. As a result, the object is no longer visible and can produce a potentially unsafe operating condition. To overcome this limitation, the soldier must be aware of the phenomenon and avoid looking at an object longer than two to three seconds. By shifting his eyes from one off-center point to another, he can continue to pick up the object in his peripheral field of vision.

Shape or Silhouette

Visual sharpness is significantly reduced at night; consequently, objects must be identified by their shape or silhouette. Familiarity with the architectural design of structures common to the area of operations will determine one's success using this technique. For example, the silhouette of a building with a high roof and a steeple can be recognized in the United States as a church, while churches in other parts of the world may have entirely different shapes.

Light Sources and Distances

The following illustration shows distances at which light sources can be seen at night with the naked eye. For observation from the air or high ground, these distances are increased two to three times.

LIGHT DISTANCES

SOURCE	DISTANCE
Vehicle headlights	4 to 8 kilometers
Muzzle flashes from single cannons	4 to 5 kilometers
Muzzle flashes from small arms	1.5 to 3 kilometers
Bonfire	6 to 8 kilometers
Flashlight	up to 2 kilometers

- Lighted match up to 1.5 kilometers
- Lighted cigarette 0.5 to 0.8 kilometers

HEARING

The soldier's hearing becomes more acute at night. Several factors contribute to this: increased concentration; sound travels farther in colder, moist air; and there is less background noise. Practice and training help overcome a soldier's lack of confidence in what he hears at night. Training enables him to discriminate multiple sounds, faint sounds, and sound-source directions. The Hearing Distances illustration shows the distances at which sounds are audible at night in open areas.

HEARING DISTANCES

SOURCE	DISTANCE
Cannon shot	up to 15 kilometers
Single shot from a rifle	2 to 3 kilometers
Automatic weapon fire	3 to 4 kilometers
Tank movement:	
..On a dirt road	up to 1.2 kilometers
..On a highway	3 to 4 kilometers
Motor vehicle movement:	
..On a dirt road	up to 500 meters
..On a highway	up to 1 kilometer
Movement of troops on foot:	
..On a dirt road	up to 300 meters
..On a highway	up to 600 meters
Small arms loading	up to 500 meters
Metal on metal	up to 300 meters
Conversation of a few men	up to 300 meters
Steps of a single man	up to 40 meters
Axe blow, sound of a saw	up to 500 meters
Blows of shovels and pickaxes	up to 1,000 meters
Screams	up to 1,500 meters

Oars on water up to 2,000 meters

SMELL

Smell is the soldier's most unused sense. Only about two percent of its potential is used. The enemy's diet usually varies from that of US soldiers. Different diets produce different characteristic human odors. People who eat a meat diet have a different odor from those who eat a vegetarian diet. Once a soldier is accustomed to the enemy's characteristic odor, it is easy to detect and differentiate at night. Practice improves skill and confidence. Sensing odors at night can be improved by facing into the wind at a 45-degree angle. Relax, breathe normally, take sharp sniffs, think about specific odors, and concentrate. The Smelling Distances illustration shows distances at which some odors are detectable at night.

SMELLING DISTANCES

SOURCE	DISTANCE
Diesel fuel	up to 500 meters
Single shot from a rifle	up to 150 meters
Heat tab	up to 300 meters

OBSERVATION EQUIPMENT

Training is the cornerstone for success in battle. The importance of training all personnel to a high proficiency for night combat, both with and without NVDs, cannot be overemphasized. The philosophy for training in the use of night vision devices is underpinned by realistic, sustained, multiechelon training focused on the mission. To sustain the soldier's skill in using NVDs, the leader must train them often enough to prevent skill decay. All training for night operations need not be conducted at night. For example, knowledge of SOPs, combat drills, and operation of thermal imagery devices can be done during daylight. This training enhances proficiency in executing these techniques at night. "Turning off the light" in training can be accomplished in several ways. Manual soldier skills can be executed by blindfolding soldiers during assembly and disassembly of equipment tasks. The M1944 goggles, with darkened lenses, may be used during daylight training. NVD operators must be rotated during training; relief operators must be trained to the same proficiency level as the primary operators. TOE levels of NVDs can be supplemented by loan items from supported units to make maximum use of- available training time. Training with NVDs should, as a minimum, include equipment adjustment, maintenance, employment, and target recognition. Developing unit and individual proficiency in using and employing night operations equipment is necessary prior to starting night tactical training. NVDs c contained in the current battery TOEs are described in the Night Vision Devices illustration on page B-8.

[Figure B-8.](#)

[Figure B-8a.](#)

REMOTE SENSORS

Remote sensors (REMS) are among the newer items added to the reconnaissance, intelligence,

surveillance, and target acquisition (RISTA) family of equipment. They are used extensively on surveillance missions; however, their ability to electronically locate a target makes them vulnerable to enemy target acquisition devices. Current force structure for light infantry calls for intelligence and surveillance to be the responsibility of MI battalions. The one exception is the use of the platoon early warning system (PEWS) which will replace the patrol seismic intrusive device (PSID) as the battery level sensor. REMS provide information for target acquisition, intelligence, and alert or early warning, depending upon the unit mission. REMS can be used to provide flank security, rear area security, and security for critical installations; to monitor objective areas or LZ/DZs; to fill gaps between units; and to protect lines of communications. Operational planning should also consider employment of REMS for effective use in a stay-behind, surveillance role during retrograde operations, or to monitor enemy advance and deployment during withdrawal movements. REMS can detect the presence of personnel or vehicles; however, these systems cannot discriminate between types of vehicles or between friendly or enemy units. For this reason, NVDs must be used in combination with sensors. Binoculars, direct fire scopes, or any image-magnifying optical equipment also enhances night missions and night operations.

PLATOON EARLY WARNING SYSTEM

The PEWS is a lightweight, self-powered, portable intrusion detection system designed for small units. The sensors are emplaced (unattended) in forward combat zones. Sensors are of two types, each of which consists of a combination of detectors. The number of each type of sensor to be employed in a PEWS set varies and depends upon specific mission requirements. There are nine sensors in a PEWS set. These sensors can operate in a radio-link or wire-link mode (see the following illustration). No single NVD or method of employment is a guaranteed solution for the sensor sections to use to conduct successful night operations. Extensive equipment familiarization and training, incorporated into tactical operations, are essential for mission success.

[Figure B-9.](#)

SEARCHING

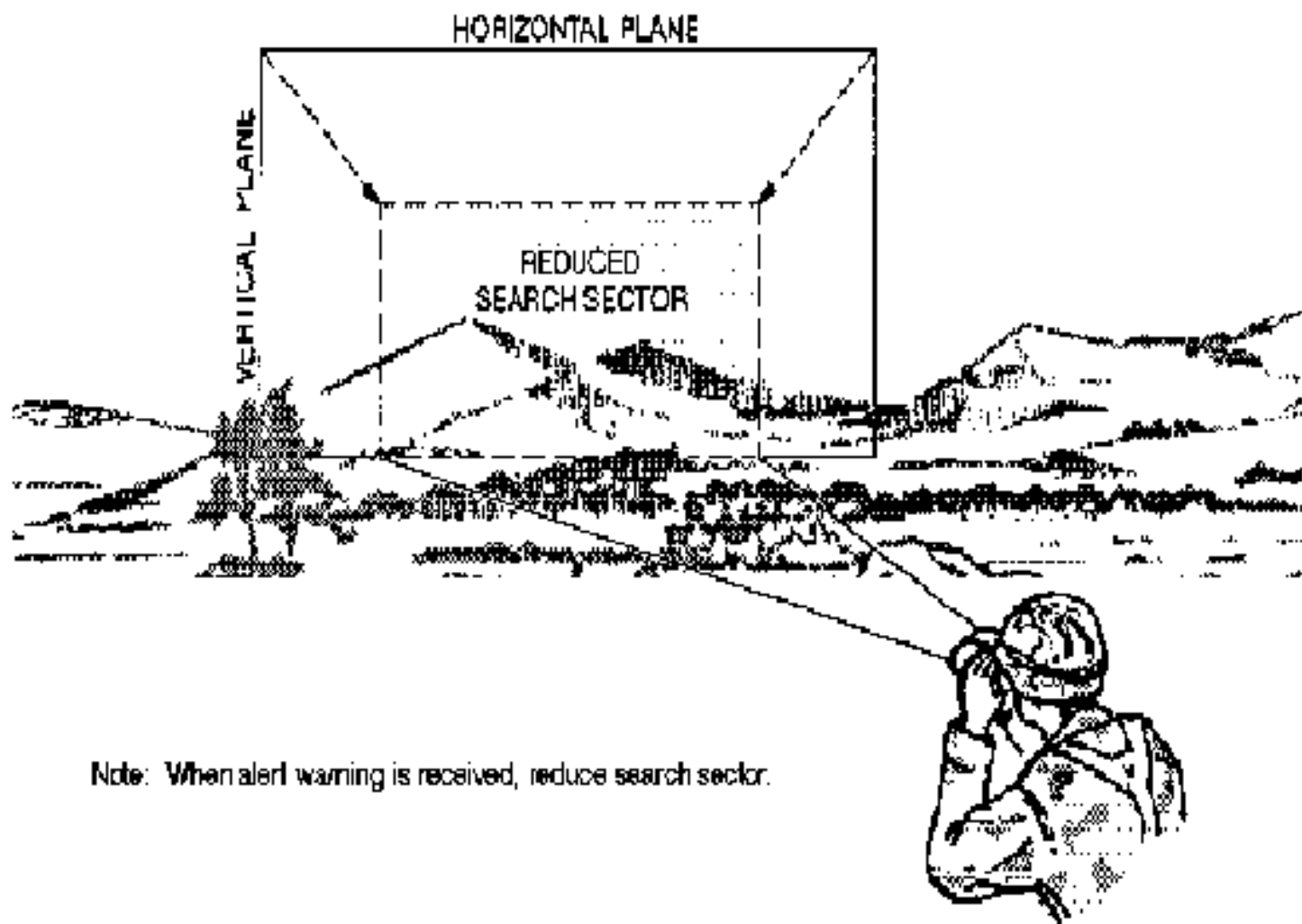

Note: When alert warning is received, reduce search sector.

ESTIMATING 20 DEGREES

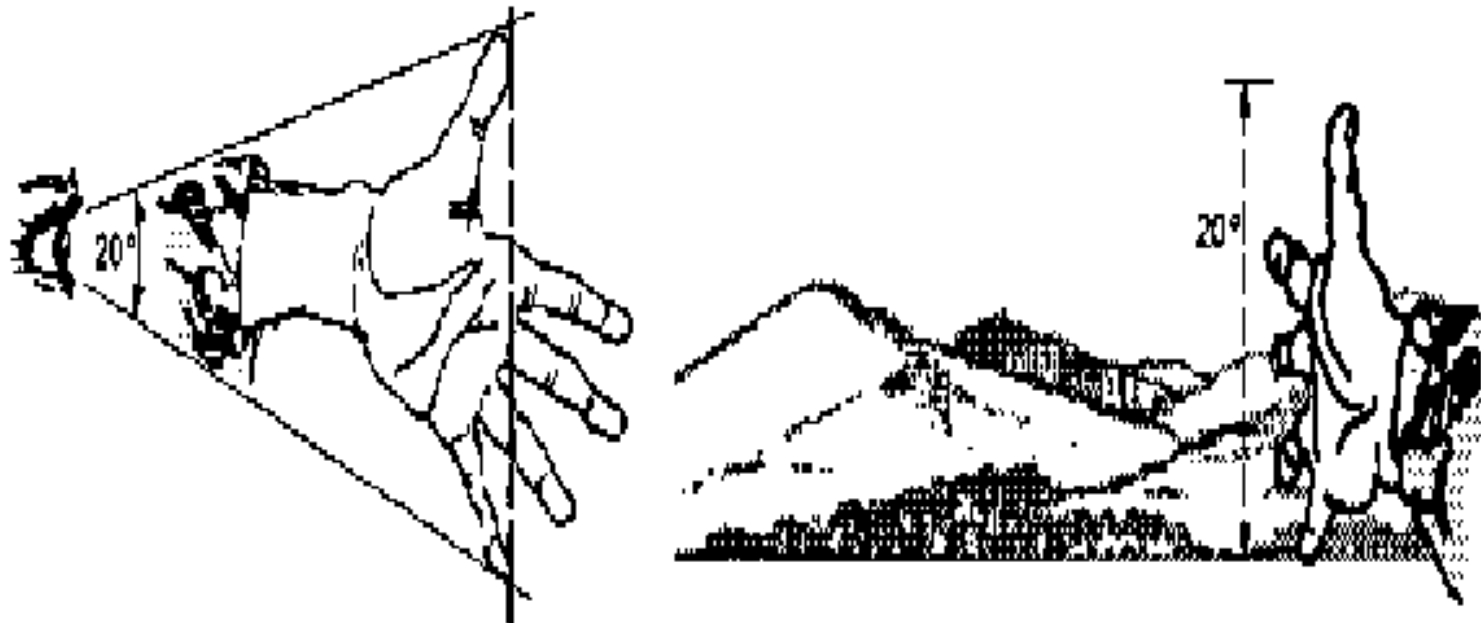

Figure B-2

HORIZONTAL SCANNING

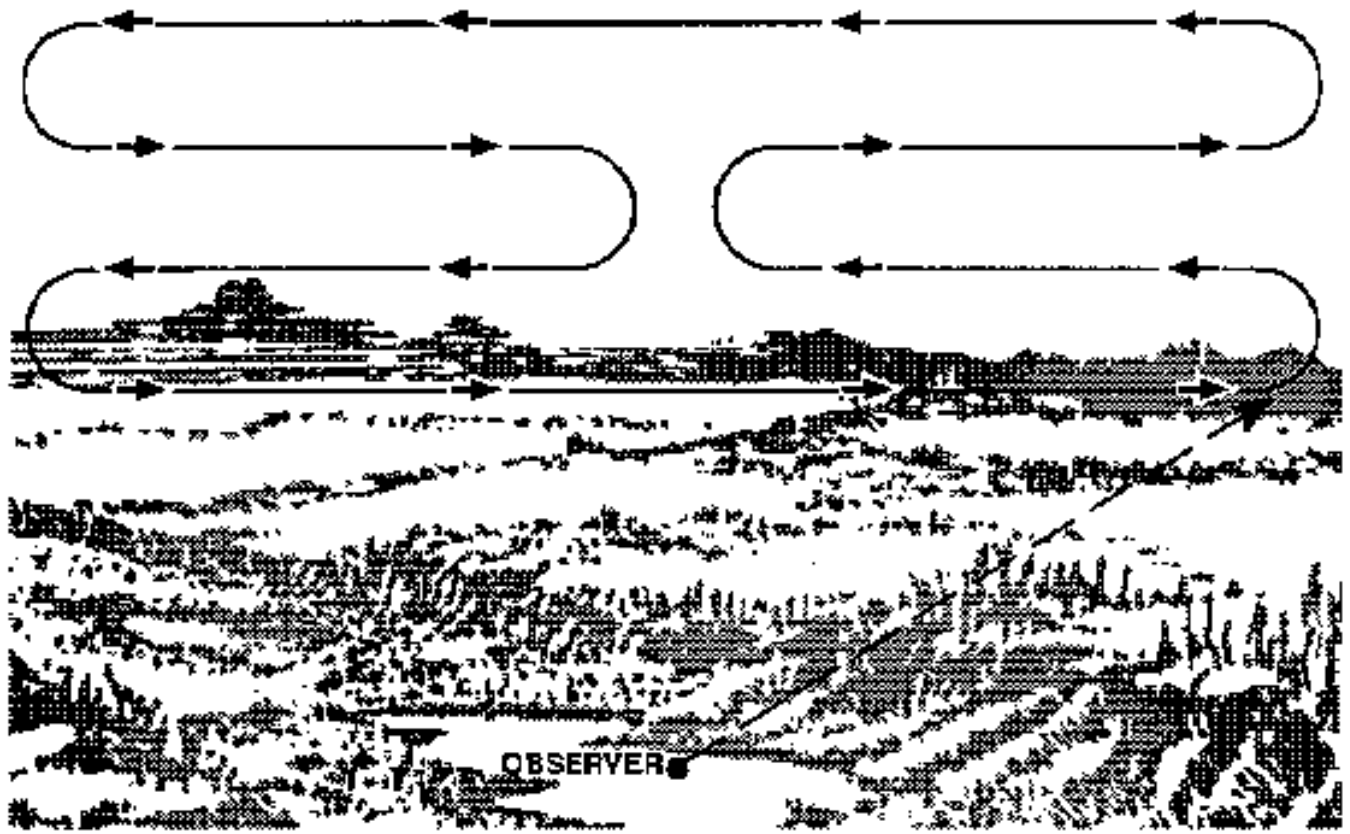

Figure B-3

VERTICAL SCANNING

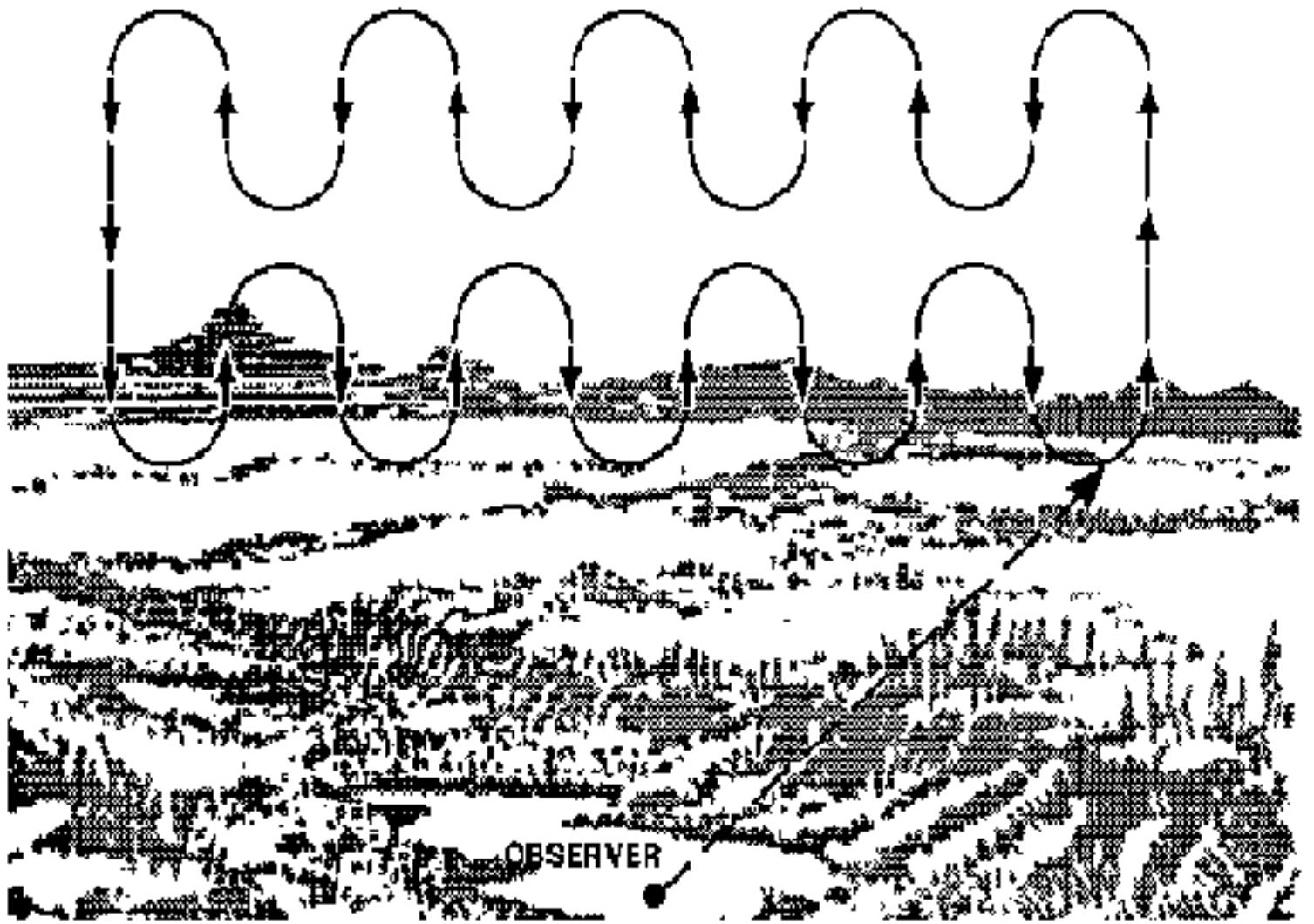
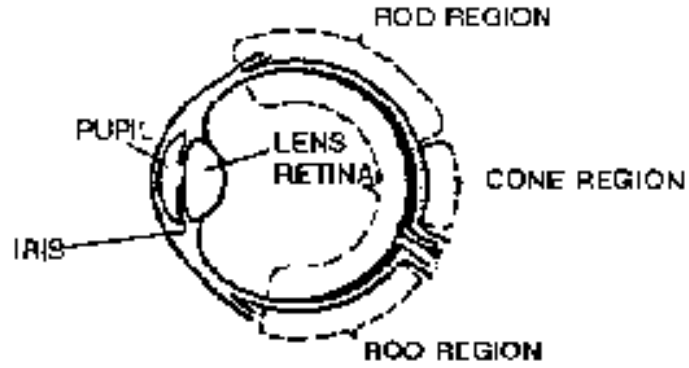

Figure B-4

CENTRAL VISION-NIGHT BLIND SPOT

DIAGRAM OF THE EYE



WHAT CAN BE MISSED AT NIGHT

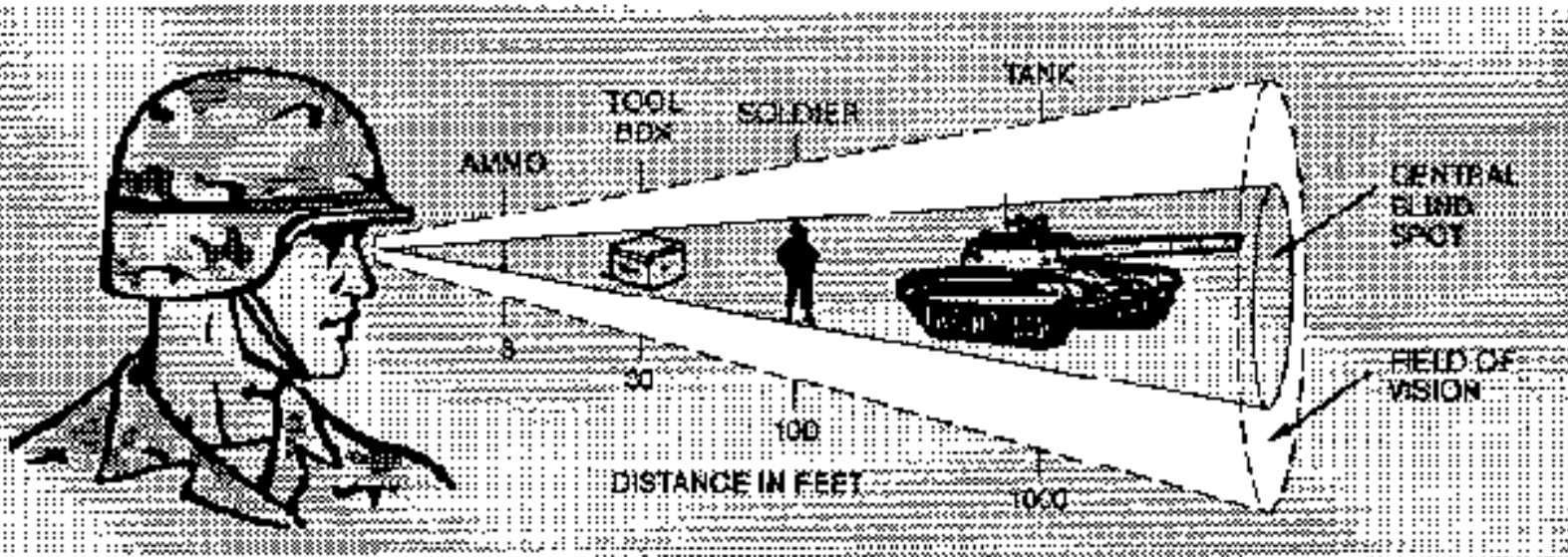

Figure B-5

TYPICAL SCANNING PATTERNS

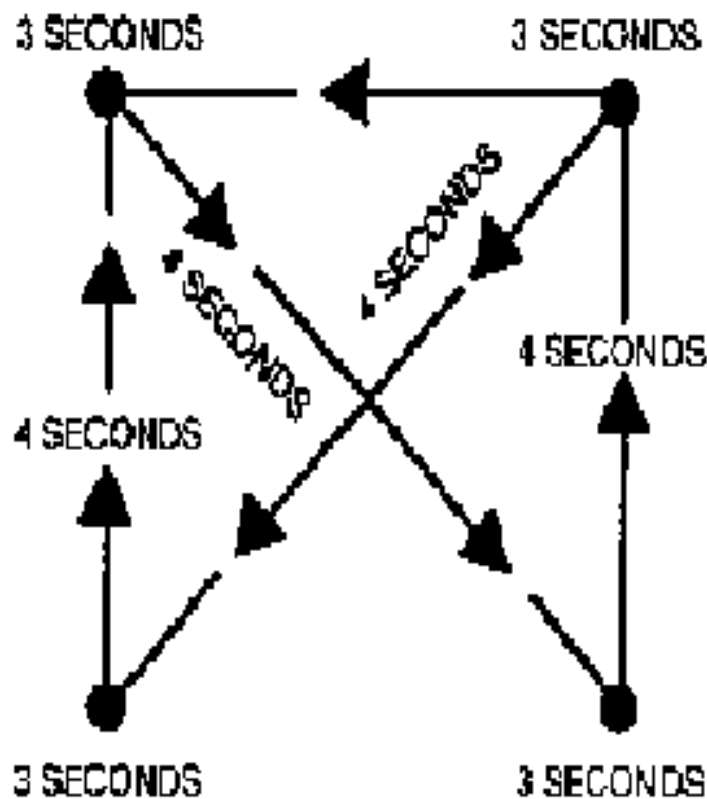
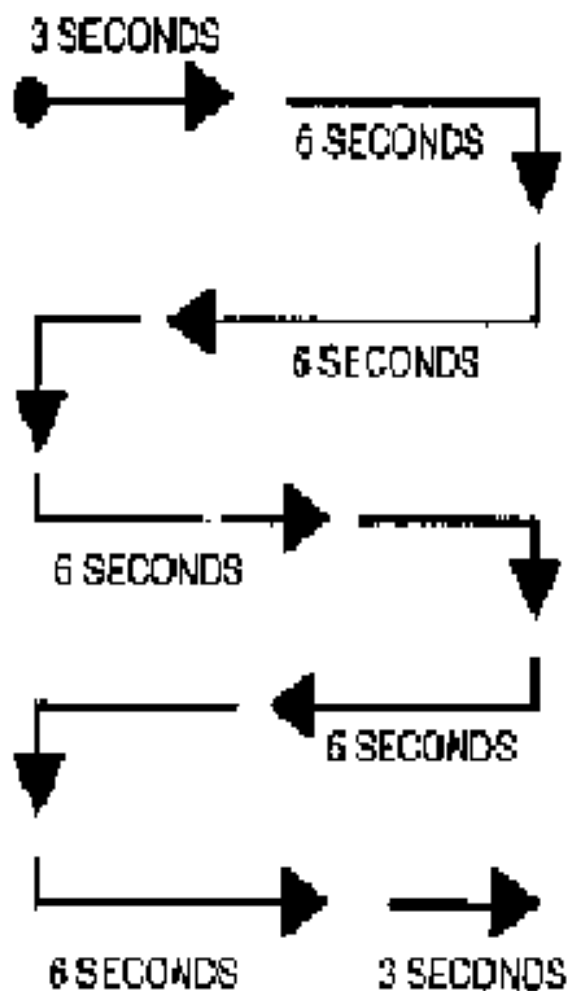

Figure B-6

OFF-CENTER VIEWING TECHNIQUE

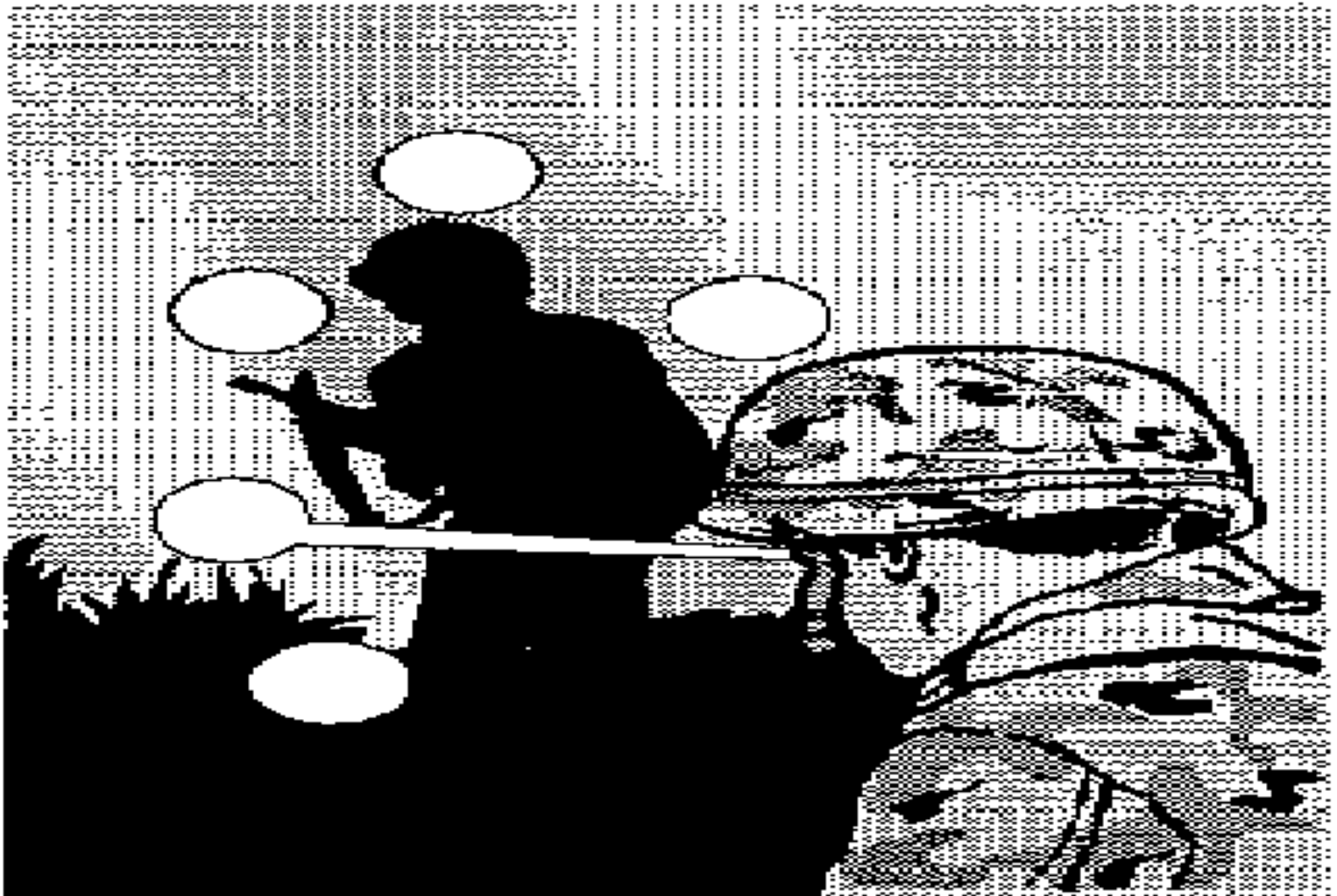

Figure B-7

NIGHT VISION DEVICES

Night Vision Sight, Individual-Served Weapon, AN/PVS-2B



The sight is compatible with the M14 and M16 rifles, M79 grenade launcher, MKT 90 millimeter recoilless rifle, and M60 machine gun. It may be employed in forward areas as a hand-held night viewer during reconnaissance and at OPs.

Characteristics:

Weight 6 pounds
Range 800 meters-moonlight
400 meters-starlight (man-size targets)
Magnification 3.6X
Field of view 10 degrees
Power BA 110AAJ (8 / 2-volt lithium)

Night Vision Sight, Individual-Served Weapon, AN/PVS-4



The sight is a second generation starlight system, employed primarily as a means for accurate aimed individual weapon fire at night. It may be used as a hand-held night observer device. It does not have a tendency to "white out" as does the AN/PVS-2B. The device mounts on the M14 and M16 rifles, M60 machine gun, M79 recoilless rifle, M249 SAW, and the M79 grenade launcher. It will replace the AN/PVS-2B.

Characteristics:

Weight 3.7 pounds
Range 800 meters-moonlight
370 meters-starlight
Magnification 3.5X
Field of view 7.6 degrees
Power BA 561/137 (2 / 2-volt lithium battery)

Night Vision Goggles, AN/PVS-5

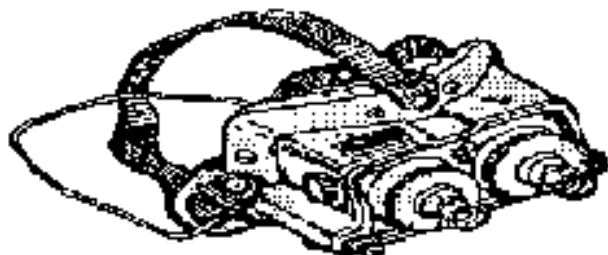

The goggles are a lightweight, battery-powered, passive night vision device worn on the head. It provides capabilities for reading, performing manual tasks, patrolling, and conducting surveillance. It has a built-in infrared light source used to provide added illumination for close-up viewing.

Characteristics:

Weight 1.9 pounds
Range 150 meters-moonlight
50 meters-starlight (man-size targets)
Magnification 1X (unity)
Field of view 40 degrees
Power BA 134/21 (2 / 2-volt lithium battery)

NIGHT VISION DEVICES (CONTINUED)

Night Vision Goggles, AN/PVS-7

These goggles will replace the AN/PVS-5. They provide improved night vision in lower light levels than the PVS-5 goggles.

Characteristics:

Weight 1.5 pounds
Range 150 meters—moonlight
60 meters—starlight (man-size target)
Magnification 4X (unity)
Field of view 40 degrees
Power BA 5567AJ (2.7-volt battery)
AA (alkaline) battery

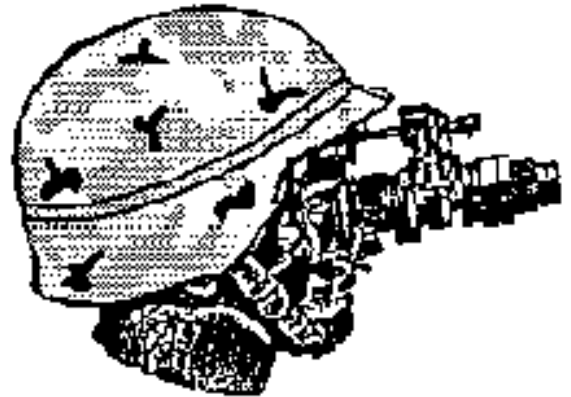

Dragon Thermal Night Sight, AN/TAS-6

Although normally employed with the Dragon weapon system, the sight may be used as a separate night viewing device. It operates by detecting and displaying (on the screen) the thermal energy which is emitted by all natural and man-made objects.

Characteristics:

Weight 22 pounds (2/1 battery and one coolant cartridge installed)
Range 1,000 meters
Magnification 4X
Field of view 3.4 degree X 6.8 degrees
Power DA 5C3AL (rechargeable 4.0-volt nickel-cadmium battery)



PLATOON EARLY WARNING SYSTEM COMPONENTS

Characteristics:

Weight 13 pounds
 Type of digging
 Type I sensor Seismic, magnetic, and soil conductance
 Type II sensor Electromagnetic, seismic, and soil conductance
 Detection range 15 meters (seismic and electromagnetic)
 Delivery means Hand amplified



2 EA
RECEIVER
GROUND STAKE



2 EA
RECEIVER, RADIO
R-1808/TRS-2



2 EA
INTERFACE WIRE LINK
IX-9738/TRS-2



2 EA
HEADSET
ASSEMBLY



2 EA
ANTENNA



2 EA
CASE, PLATOON EARLY WARNING
SYSTEM, CY-7524/TRS-2



10 EA
DETECTOR ANTIINTRUSION
ET-677/TRS-2



20 EA
HOLDING
ASSEMBLY



2 EA
TECHNICAL
MANUAL



4 EA
CARRYING
STRAP

APPENDIX C

Determining Direction in the Field

This appendix is an overview of how to determine direction using issued equipment and field-expedient methods. The use of stars, the sun, and geographical reference points with maps, compasses, and other equipment aid in land navigation. FM 21-26 contains additional information on equipment and methods for land navigation.

COMPASS

The lensatic compass consists of a case in which a magnetic dial is mounted on a pivot so that it can rotate freely when the compass is held level (see the Lensatic Compass illustration). Printed on the dial in luminous figures are an arrow and letters E and W. The arrow always points to magnetic north and the letters fall at east (E, 90 degrees), and west (W, 270 degrees). South is at 180 degrees. On the dial are two scales. The outer scale is in mils and the inner scale is in degrees. The front sight is a sighting wire set into a slot in the cover. The rear sight has a slot for sighting on the object and a lens for reading the dial.

GENERAL RULES

Two general rules should always be followed when using the compass.

Rule 1

Keep the compass away from metal objects and high-voltage wires. The north arrow of the compass is controlled by lines of force in the earth's magnetic field. Since these force lines are disturbed locally by small amounts of iron and electric fields, these things will produce error in a compass reading. Even metal rimmed glasses will affect the compass and the effect will be greater as the mass of the object or the strength of the field increases. The extent of the effect can be determined by holding the compass in the palm of the hand and slowly walking away from the object until the dial remains still.

[Figure C-1.](#)

Rule 2

Keep the compass closed when not in use. The compass is a delicate instrument and may easily be damaged. It should always be properly closed and returned to its carrying case when not actually being used.

USE OF THE CENTERHOLD TECHNIQUE

The best method for using the lensatic compass under normal conditions is the centerhold technique (see Centerhold Method illustration below). However, this method is used only when a precise direction is not required. To use this method--

- Open the compass so that the cover forms a straight edge with the base. The lens of the compass is moved out of the way.
- Place your thumb through the thumb loop, form a steady base with your third and fourth fingers, and extend your index finger along the side of the compass.
- Place the thumb of the other hand between the eyepiece and the lens, extend the index finger along the remaining side of the compass, wrap the remaining fingers around the fingers of the other hand, and pull your elbows firmly into your side. This will place the compass between your chin and your belt.
- Measure an azimuth, turn your entire body toward the object, and point the compass cover directly at the object. Look down and read the azimuth from beneath the fixed black index line. This method can be used at night.
- Keep from going in circles when you are land navigating and stop occasionally to check the azimuth along which you are moving. Also, you can move from object to object along your path by shooting an azimuth to each object and then moving to that object. Repeating this process while you navigate should keep you straight.

USING COMPASS AT NIGHT

Different models of the lensatic compass vary somewhat in the details of their use at night, but the principles are the same. Mounted over the dial, in addition to the stationary glass cover or fixed crystal, is a movable crystal; on this movable crystal is at least one luminous line. To preset the compass for night use, follow these steps.

Light Source Available

Holding the compass in the palm of the hand, rotate it until the desired azimuth falls under the index line. Hold the compass steady so that the desired azimuth remains under the index line, and turn the movable crystal until the luminous line comes over the north arrow.

[Figure C-2.](#)

Light Source not Available

An azimuth may be set on the compass by the click method. As the movable crystal is rotated, a series of clicks is heard. Each of these clicks represents 3 degrees. If the desired azimuth is divided by 3, the number of clicks which can be set off can be determined. To set the azimuth on the compass, rotate the movable crystal until the long luminous line is directly over the index line, and then, holding the compass by the movable crystal, rotate the body of the compass clockwise the desired number of clicks.

Selecting an Object on the Azimuth

With the compass preset as described above, rotate the compass until north arrow falls directly under the luminous line. The body of the compass and the sighting wire are pointing along the required azimuth. Look through the sighting slot and find an object along the sighting wire. (see the Compass-to-Cheek

Method illustration). If in a party, it may be expedient to send a man ahead as far as he can be seen and direct him right or left until he is on the desired azimuth. Then move up to his position, reorient the compass with the north arrow under the luminous line, and repeat the process.

Note: The presetting procedure outlined above for using the compass at night may also be used during daylight.

USE OF "OFFSET"

To compensate for our natural tendency to drift from our desired azimuth, especially at night, it may be desirable to offset the compass a few degrees to the left or right of the desired azimuth. The procedure should be used with caution and the amount of "offset" used will be dependent upon the distance to be traveled.

ORIENTATION OF THE MAP USING THE COMPASS

Place the compass on the map so that the cover of the compass is pointing toward the top of the map. Align the sighting wire or the straightedge of the compass over a north-south grid line and rotate the map and compass together until the north arrow of the compass points in the same direction and number of degrees as shown in the current (updated) grid-magnetic angle.

[Figure C-3.](#)

FIELD-EXPEIDIANT METHODS

When a compass is not available, different techniques can be used to determine the four cardinal directions. These techniques do not require special navigational equipment.

SHADOW-TIP METHOD

This simple and accurate method of finding direction by the sun consists of four basic steps. The shadow-tip method is a simple and quick way to determine directions without a compass (see the Shadow Tip illustration on page C-4).

Step One

Place a stick or branch into the ground vertically at a fairly level spot where the sun will cast a distinct shadow. Mark the shadow tip with a stone, twig, or other means. This first shadow mark is always the west direction.

Step Two

Wait 10 to 15 minutes until the shadow tip moves a few inches. Mark the new position of the shadow tip in the same way as the first.

Step Three

Draw a straight line through the two marks made on the shadow tips. This is an east-west line.

Step Four

Stand with the first mark (west) to your left and the second mark to your right. The other directions are simple; north is to the front and south to the back. Remember, the first shadow-tip mark is always in the west direction, everywhere on earth. To find north and south directions, draw a line at a right angle to the east-west line at any point. This is the north-south line. Remember the following rules about shadow-tip directions:

- The sun rises in the east and sets in the west-- everywhere on earth.
- The shadow tip moves in the opposite direction.
- The first shadow-tip mark you make is always west, and the second mark is always east.

WATCH METHOD

To determine direction using the watch method, you must use a nondigital watch. Direction is determined using the hour hand and face of the watch. This method is not as accurate as the shadow-tip method. When you are north of the equator (northern hemisphere), point the hour hand at the sun. South will be halfway between your hour hand and 12 o'clock, local standard time. If you are on daylight saving time, south will be midway between the hour hand and 1 o'clock (see the Watch Method illustration). When you are south of the equator (southern hemisphere), you use the watch differently. Point 12 o'clock at the sun. Then, halfway between 12 o'clock and the hour hand is north (see the Watch Method illustration). During daylight saving time, point 1 o'clock at the sun; during daylight saving time, north is midway between 1 o'clock and the hour hand.

[Figure C-4.](#)

[Figure C-5.](#)

STAR METHOD

On a clear night, many stars are visible, and if you walk toward the North Star, you will be walking northward. The North Star, however, is not the brightest star in the sky and is sometimes hard to find. To locate the North Star, you should know that--

- All other stars revolve around the North Star.
- The North Star is the last star in the handle of the constellation Ursa Minor (Little Dipper), but the complete Little Dipper is often difficult to see.
- The easiest way to locate the North Star is by using the constellation Ursa Major (Big Dipper). A straight line drawn between the two stars (pointers) at the end of the Big Dipper's bowl will point to the North Star. The distance to the North Star is about five times the distance between the pointers.
- Directly across from the Big Dipper is the constellation Cassiopeia's chair. It is made up of five stars and resembles a lopsided "M" or "W" depending on its position in the sky. The North Star is straight out from the center star of Cassiopeia's chair. It is almost equidistant between the Big Dipper and the Cassiopeia's chair. (see the Big Dipper illustration). If your are south of the equator you can use the constellation Southern Cross to help you determine the general direction of south. The Southern Cross is a group of four bright stars in the shape of a cross that is tilted to one side. The two stars forming the long axis, or stem, of the cross are called pointers. To determine which direction is south, imagine the long axis extending from its foot five times its length. The point

where this imaginary line ends is in the general direction of south (see the Southern Cross illustration). Look straight down from this imaginary point to the horizon and select a landmark.

[Figure C-6.](#) [Figure C-7.](#)

LENSATIC COMPASS

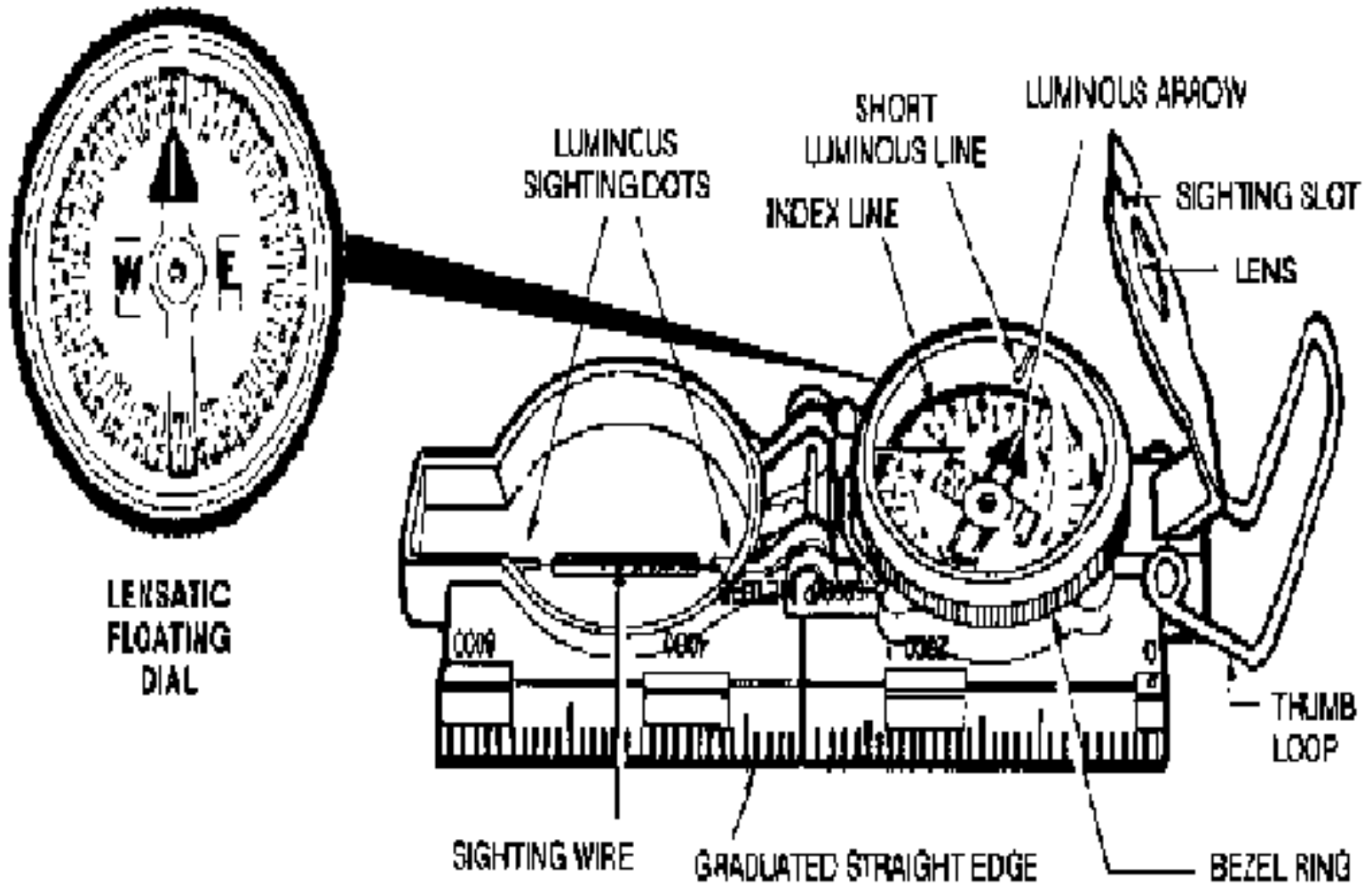

Figure C-1

CENTERHOLD METHOD

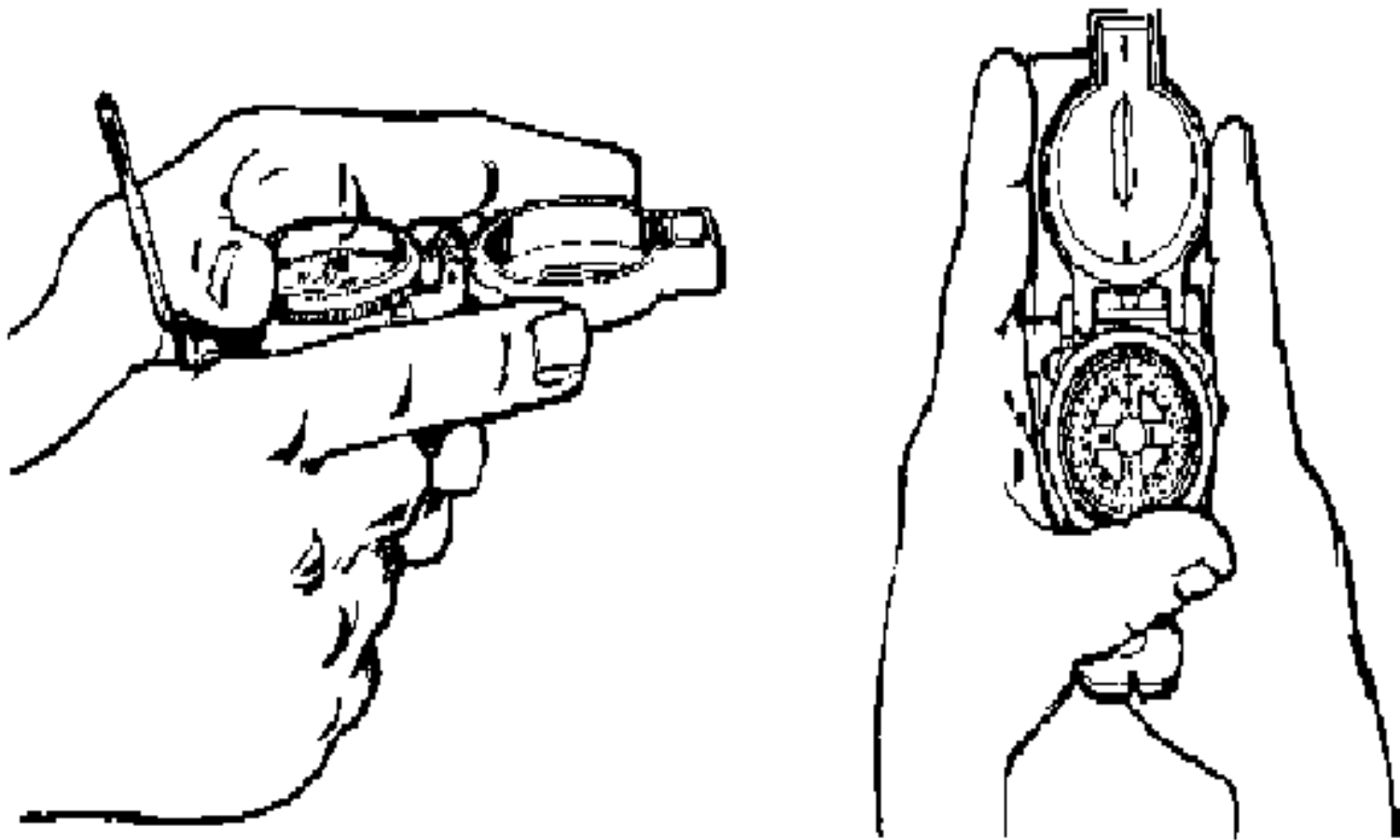
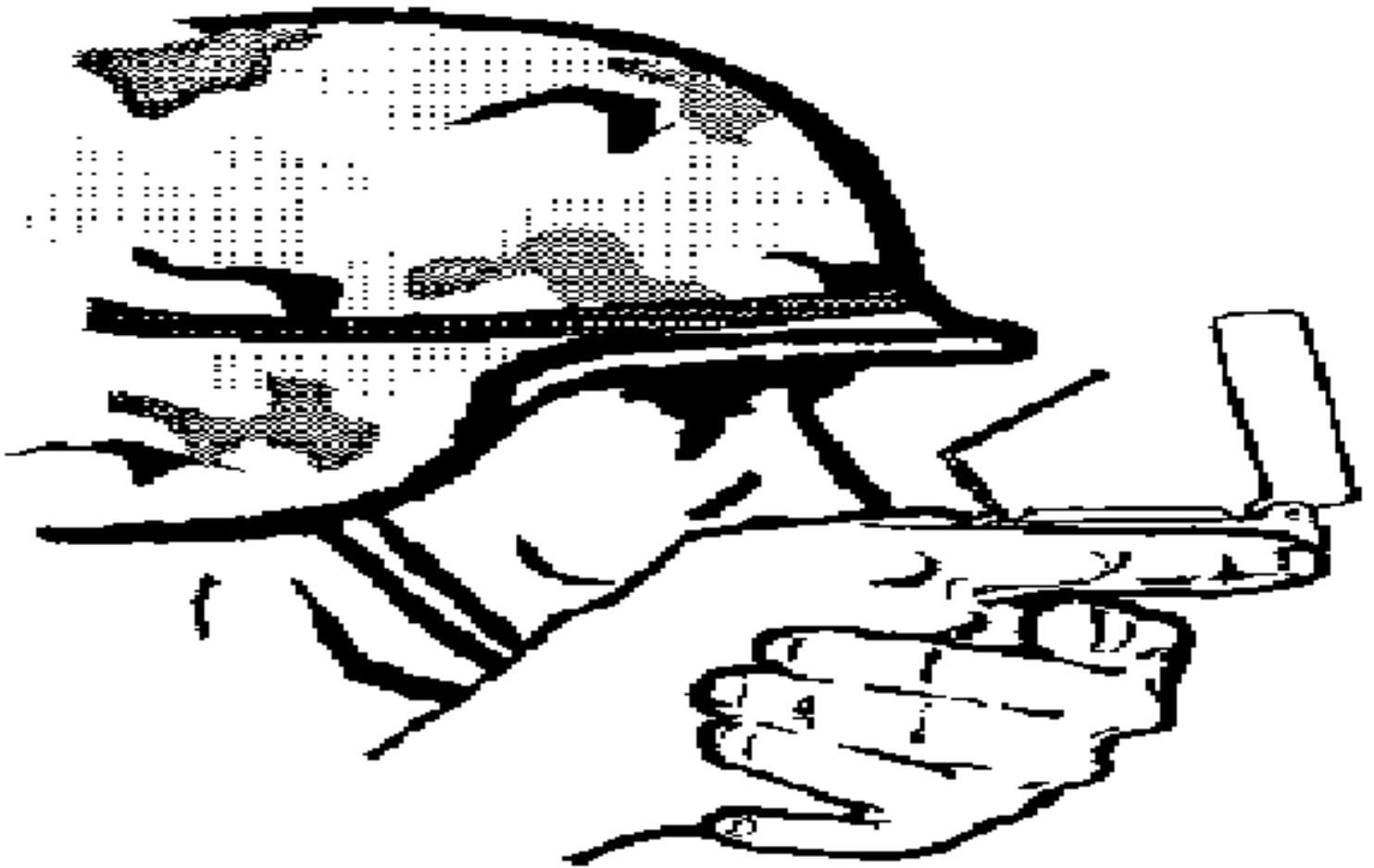

Figure C-2

COMPASS-TO-CHEEK METHOD



SHADOW TIP

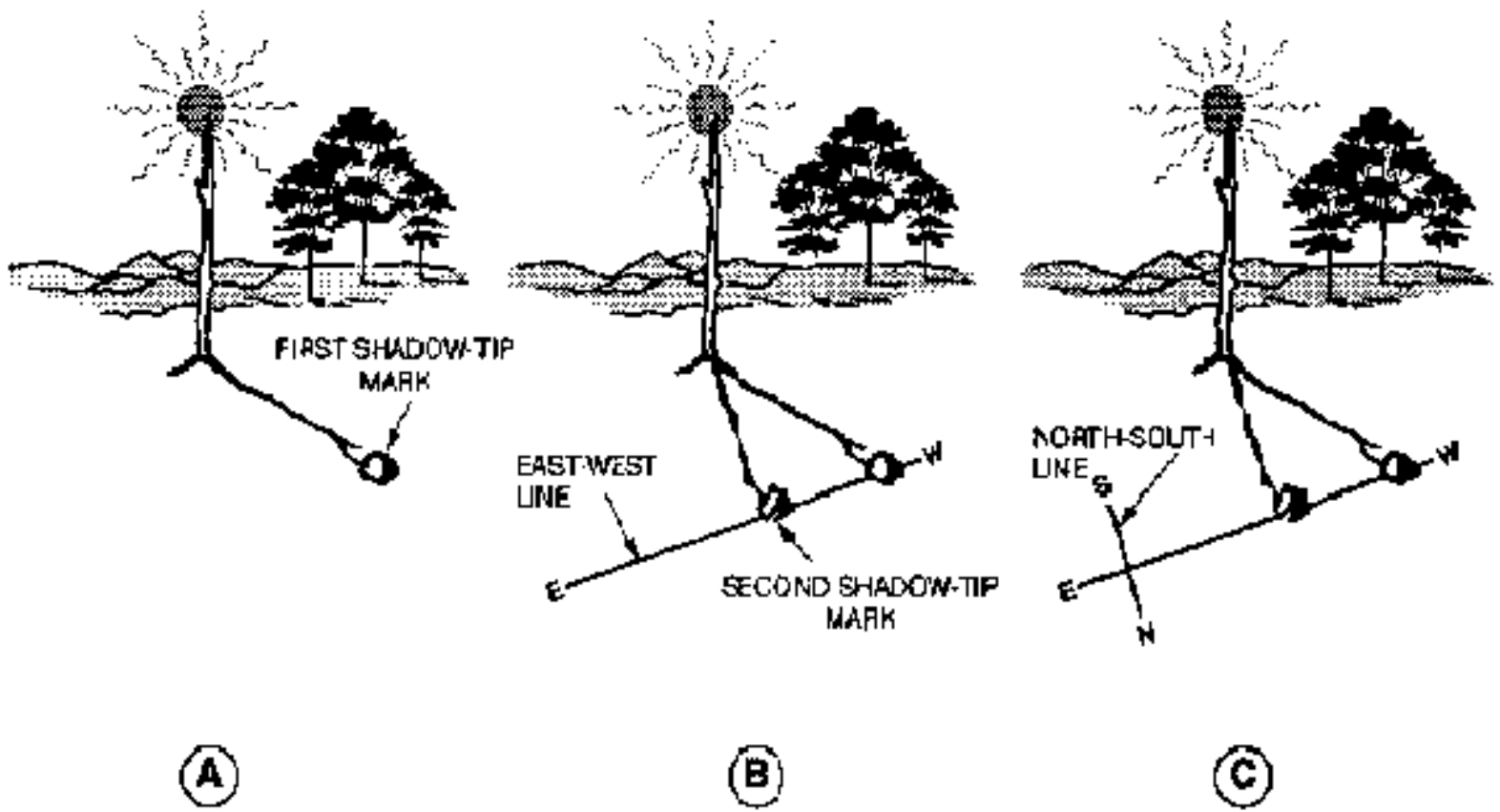

Figure C-4

WATCH METHOD

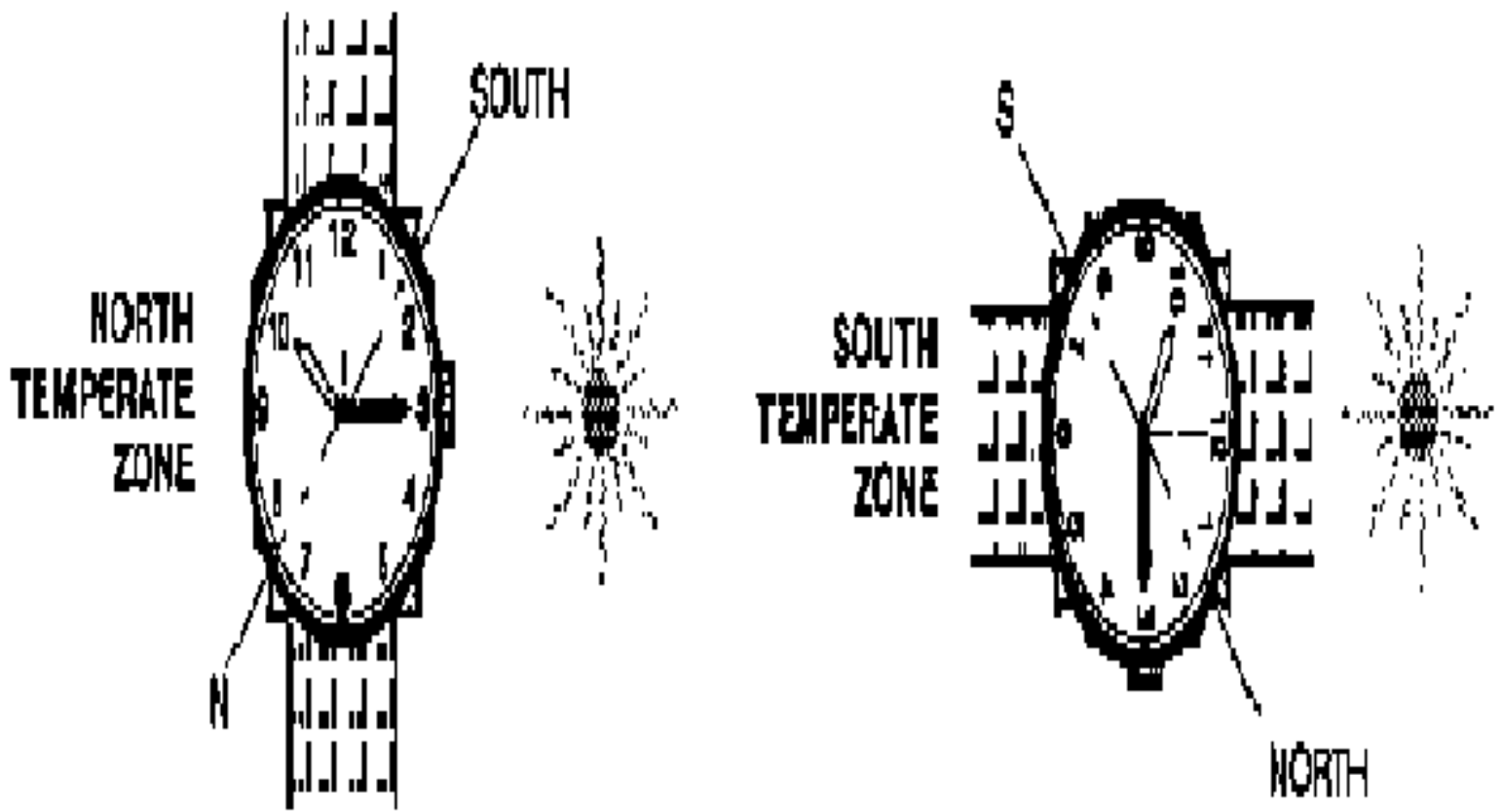

Figure C-5

THE BIG DIPPER

BIG DIPPER

CASSIOPEIA

NORTH STAR

τ

κ

α

β

γ

δ

ε

θ

α

β

γ

δ

ε



Figure C-6

SOUTHERN CROSS

SOUTHERN CROSS

IMAGINARY POINT

SOUTH LANDMARK

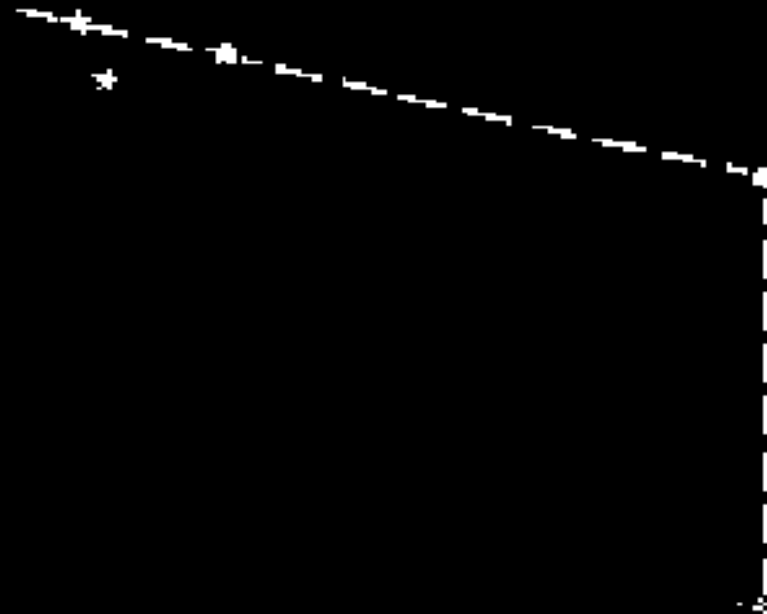

Figure C-7

APPENDIX D

Stealth

This appendix brings into focus the need to plan for movement by vehicle and for movement by foot so that the probability of detection is minimized. Stealth is one of the primary factors in the survivability of the ADA sensor sections.

MOVEMENT PLANNING

Night operations depend upon direction, control, and surprise for success. Direction in the attack facilitates a coordinated effort to maximize combat potential. Control ensures that units are mutually supporting and that the proper NAIs are observed. Surprise, through speed and secrecy, is the key to minimizing the enemy's ability to react or to focus combat power against the sensor section. The ability to successfully conduct these operations places emphasis on small unit skills to navigate and move silently through dense terrain.

NAVIGATION

Navigation at night is different from daylight navigation. Shapes and sizes are distorted and colors fade. However, towns and radio towers may be easier to recognize. Night navigation, like day navigation, uses terrain association and or dead reckoning. Terrain association uses a general direction of travel coupled with the recognition of prominent map and ground features. Dead reckoning uses a compass direction and specific distances or legs. The basic requirement while moving at night is to remain oriented. Resection helps determine location while moving. Proficiency in resection results from a thorough map and terrain analysis. Map and terrain analysis is critical due to the distance distortion which occurs at night. Distance is judged partly by object size, color, depth perception, and other factors which are degraded at night. As a result, small objects seem farther away and large objects seem closer. Bright objects seem closer than dull ones. Forests or groves of trees seen from a distance may appear to be hills in dim light.

MAP ANALYSIS

When a sensor section enters a new area, the section chief must orient the map to the terrain to get the "lay of the land": local drainage and relief, dominant terrain features, how the terrain looks from other features, and most importantly, how the area looks at night. To know the area, the section chief must walk it in all directions, both day and night.

TERRAIN ANALYSIS

During a reconnaissance, the sensor section chief compares the terrain with the mental images developed during map analysis. This confirmation and modification of the initial analysis fixes the land patterns and important features in memory.

ROUTE SELECTION

METT-T is the criterion used to determine the route used for night movement. Since more than one route may satisfy the requirements for METT-T, select the one that offers ease of navigation. Night travel is strenuous, often done when soldiers are tired, adding to physical and psychological stress. Ease of navigation contributes both to maintaining direction and control. The selected route is subjected to further analysis using the factors of observation and fields of fire, cover and concealment, obstacles, key terrain, and avenues of approach (OCOKA). METT-T may make one of these factors more critical, such as terrain, cover, or avenues of approach. As the route is analyzed, it is divided into segments or legs. Legs represent a way to maintain control. Each leg begins and ends either with a change in direction or a prominent terrain feature. The location where the leg begins is a checkpoint. Checkpoints provide a sequential series of guides to use for orientation and control. As before, each leg is analyzed using OCOKA. OCOKA helps determine probable hasty ambush sites, likely areas the enemy may use for movement, and where observation may improve.

An additional consideration is given to identifying features on the far side of each checkpoint. The features will act as catchpoints in case checkpoints are missed. The catchpoint provides a quick and easy method to reorient movement. Linear features such as a river, road, or ridge are the best features to use as catchpoints. Every effort is made to conduct a reconnaissance of the route before moving the section. The ideal is both a day and night reconnaissance. As the reconnaissance is conducted, aids to orientation are confirmed, adjusted, or added. Terrain features (hills, cliffs, rivers, ridges, and draws) and man-made features (towers, buildings, bridges, and roads) are all aids to navigation. The best navigational aid, however, is a guide who knows the area. A final ingredient is the reorientation plan. Reorientation is planned throughout the movement: checkpoints, catchpoints, and position locators are aids. Nevertheless, sensor sections may get lost. Therefore, section chiefs must plan on how to recover, reorient, and complete the mission. Plan for this contingency during the reconnaissance. Add extra checkpoints, if necessary. Look for distant terrain features to use for resection. Plan to resection off indirect fire on known locations. By planning on how to react if the section becomes lost, the probability is diminished.

MOVEMENT (MANUALLY)

When operating without the radar (not yet emplaced/operational) often the sensor section will leave their vehicle in a location which is easy to camouflage. This means that the section can exercise an increased stealth posture by moving on foot. This will increase their probability of keeping their position and movement undetected by the enemy.

NIGHT WALKING

Night movement on foot requires the use of different muscles than day movement. Therefore, to move with stealth at night requires practice. Walking at night places more strain and exertion on the muscles of the thighs and buttocks as opposed to the calf muscles used for daylight travel. Night movement requires that these muscles become accustomed to taking short, careful steps. The object is to make cross-terrain

travel as natural as walking along a sidewalk. Night walking proficiency is gained through practice. Begin by looking ahead, then slowly lift the right foot approximately knee high, and balancing on the left foot, ease the right foot forward to feel for twigs and trip wires. Keep the toes pointed downward. The lead foot should touch the ground about six inches to the front. As the toes come to rest, the soldier feels for the ground with the outside of the toe of the boot. Then he settles the foot on the ground. As this step is taken, the boot is used to feel for twigs and loose rocks. Confident of solid, quiet footing, the soldier slowly moves his weight forward, hesitates, then begins lifting his left foot (see the following illustration). The process is repeated with the left foot. This method of balanced, smooth walking at night reduces chances of tripping over roots and rocks and reduces noise. Soldiers conditioned to move at night, using the larger muscle groups of the leg, are able to travel farther with less fatigue. Scanning the horizon helps the soldier keep his balance and maintain proper orientation. It allows him to detect light, contrast, and motion, which may indicate an enemy ambush.

[Figure D-1.](#)

STALKING

Stalking is best described as night walking in a crouch; but, very slowly. The soldier is usually watching the enemy, stalking him by eyesight. When close to the enemy, squinting helps conceal light reflected by the eyes. Breathe slowly and through the nose. If the enemy looks in the direction of the stalker, the stalker freezes, balanced or not. Movement should take advantage of the background to blend with shadows and prevent glare or contrast. Movement is best conducted during distractions such as gusts of wind, vehicles moving, loud talking, or nearby weapons fire.

CRAWLING

All crawling techniques feel awkward at first. Practice increases expertise. Crawling is more comfortable when pads are used on the knees and elbows; however, ensure that the binders or tapes holding the pads on do not cut off blood circulation. The fastest crawl uses the single-side, hand-and-foot method. Movement is accomplished by pressing the right or left hand and foot against the ground and either pushing or pulling forward. This method sacrifices noise discipline and is the least useful in the final phase of stalking. A second method involves using the opposite hand and foot. This is done by pressing down with an arm and a foot on the opposite side and resting on one hip. In this way, the body is pulled forward with the left hand and right foot. As the soldier reaches forward again he is resting on his left hip. He then pulls his body forward using the right hand and left foot, and rests on his right hip. This method is slower and quieter than the first method. The slowest and quietest technique uses the elbows and toes of the boots. It is executed by lifting the body up on elbows and toes of the boots, slowly pushing the body forward, resting, and repeating the process. Each movement is measured in inches. The position of the head is important while crawling. Before moving, always look to the front for obstructions and or enemy activity. Lift the head slowly off of the ground, look to the front, from left to right, and low to high. Squint with the eyelids to prevent undue light reflection off the eyes. Then lower the head to the ground, facing either to the left or right. Another precaution before moving is to feel to the front for obstructions such as roots that may snag clothing and twigs and rocks that may make noise. Remove or go around them.

LIGHT AND NOISE DISCIPLINE

The chief factor which gives away a position is the lack of light and noise discipline. To overcome this shortfall, the section must practice light and noise discipline and the section chief must check. Communications at night calls for the section chief to use different methods than during daylight. For instance, arm-and-hand signals used during the day may not be visible during darkness. Signals are used to pass information, identify locations, control formations, or initiate activity. The key to tactical communications is simplicity, understanding, and practice. Signals should be an integral part of the unit SOP. Signals should be made as simple as possible to avoid confusion. The most common signals relate to the senses: hearing, feeling, and seeing. Audio signals include radio, wire telephones, messengers, and the grating or clicking of objects together. Control at night involves some verbal communications, but do not talk in a natural tone of voice--whisper instead. To do this, take a normal breath, exhale half of it, and then whisper into the other person's ear using the remainder of the breath. The radio and telephone may not be suitable at night. If either is used, take certain precautions. Noise travels farther at night. So will the static of the radio, the passing of messages, and the ringing of the telephone. These are violations of noise discipline. They can be reduced by planned signals or clicks. Headphones also reduce the amount of noise by both devices. Rocks and other objects may be used to transmit audible signals. Rocks may be tapped or scraped together; they can be scraped against a tree or rifle stock to pass a message. These signals are rehearsed. There is a signal and a reply to indicate the signal was received. Other audible signals are whistles, bells, sirens, clackers or "crickets," and horns. The device or method chosen depends on simplicity and security. Visual signals are an alternative to audio signals. These signals may be active or passive and include a wide range of alternatives. The key to visual signals is to ensure they are noticed and identifiable. Some passive signals are--

- Sticks indicating a direction.
- Light paint.
- Tape.
- Rock formations.
- Markings in the ground.
- Powder.
- Luminous tape.

Conversely, active signals include--

- Flares.
- Flashlights.
- Illumination rounds (M203, mortar, and artillery).
- Chemical lights.
- Infrared strobe lights
- Strobe lights.
- PVS-5, NVD.
- Burning fuel (saturated sand in a can).
- Luminous compass dial.

These signals can be used to identify a critical trail junction, initiate an attack, mark caches, or report that a danger area is clear. White powder can be used to indicate direction at a confusing trail intersection; star clusters can signal the initiation of an attack or raid; chemical lights can signal a unit cache; and a flashlight with a blue filter (using an X cut out of the filter) can signal all clear to a unit crossing a danger area. The possibilities are endless; but the section chief ensures that each signal used is understood by each soldier in the section. The last type of signal deals with the sense of feel. Communications to a trail watcher out from an observation point (OP), without disclosing positions, may employ wire, string, or rope as signal devices. The wire is usually secured to the arm or leg; using prearranged signals, activity is relayed between the main body and the security elements. Two pulls on the wire may mean ground-mounted force approaching, while three pulls may indicate a convoy. Regardless of the type of signal used, it must be simple, easy to understand, and practical. Signals at night aid in control, enhance security, and support surprise. Plan the type of signals based upon section activity and desired results. Then brief the soldiers and have them practice the signals.

SOLDIERS MOVING AT NIGHT



AVOID SWISHING
LIFT KNEES HIGH



PUT TOE DOWN FIRST

APPENDIX E

Position Security

This appendix discusses measures for security of the ADA sensor section position. One of the primary tasks for the ADA sensor section chief is to plan the defense of the section or individual position. Such things as setting up reference points, assigning sectors of fire, and placing claymore mines, are a part of the section chief's responsibility.

NIGHT SECURITY

Sensor section chiefs address security, target detection, engagement of targets, fire support, illumination, and fighting positions in their defensive scheme. Security of the section night defensive position (NDP) consists of both active and passive measures.

ACTIVE MEASURES

Physical security is all of the measures which keeps the section from being surprised. This includes security in all directions. Rock-filled cans suspended on barrier wire or across suspected avenues of approach can provide intrusion warning. The section chief should control the section fires with tracer fire. All section members should engage the targets marked by the section chief. Each position should have an NVD. These allow the chief to be proactive instead of reactive. This ensures that every man adjusts to the changing light and noise conditions, and is dressed, equipped, and ready for action.

PASSIVE MEASURES

Passive measures include camouflage of positions, control of movement, light and noise discipline, and limiting radio traffic. Soldiers must also pick up their litter.

NIGHT TARGET DETECTION

Target detection during the day is easier than at night since terrain feature references can be seen. At night, two reference methods are range cards and a grid matrix.

RANGE CARDS

A range card is a rough sketch of the terrain around a weapon. It is prepared for each weapon system and sensor. The card shows sectors of fire, final protective line (FPL), or principal direction of fire (PDF) of the weapons, targets, and ranges to them. Each soldier prepares at least two copies of a range card for his position. The soldier keeps one copy at the position and gives one copy to the section chief. The section

chief makes a section sector sketch, using the individual position's range cards.

GRID MATRIX

A grid is created using luminous tape or chemical lights with minimal light exposure. The best grid is a three-spot by two-spot grid per sector (see the Grid Matrix for Target Reference illustration on page E-2). The spots serve two purposes: reference points for targets, and a method to adjust the height of direct fire (the lower the rounds, the more effective they are). Once the sector is established, have each section member memorize the terrain. The luminous markers help identify terrain. When sounds are heard, a target location can be referenced. Oftentimes, targets cannot be seen, but the direction can be determined and fire placed on it.

[Figure E-1.](#)

ENGAGEMENT OF TARGETS

Leaders establish how targets should be engaged; for example, the first targets engaged are those that threaten the position. Leaders verbally, and with tracer fire, establish and reestablish target priorities during contact. Enemy targets are attacked without revealing friendly positions, if possible. Command detonating, well-placed claymore mines, will serve to surprise, kill, and silhouette the attackers. Hand grenades also stun or surprise the enemy or injure and kill him. The M203 grenade launcher illumination round is good for short term illumination of small areas to ward off probes. This is preferable to illumination that lights the entire sector--friendly and enemy.

GRID MATRIX FOR TARGET REFERENCE

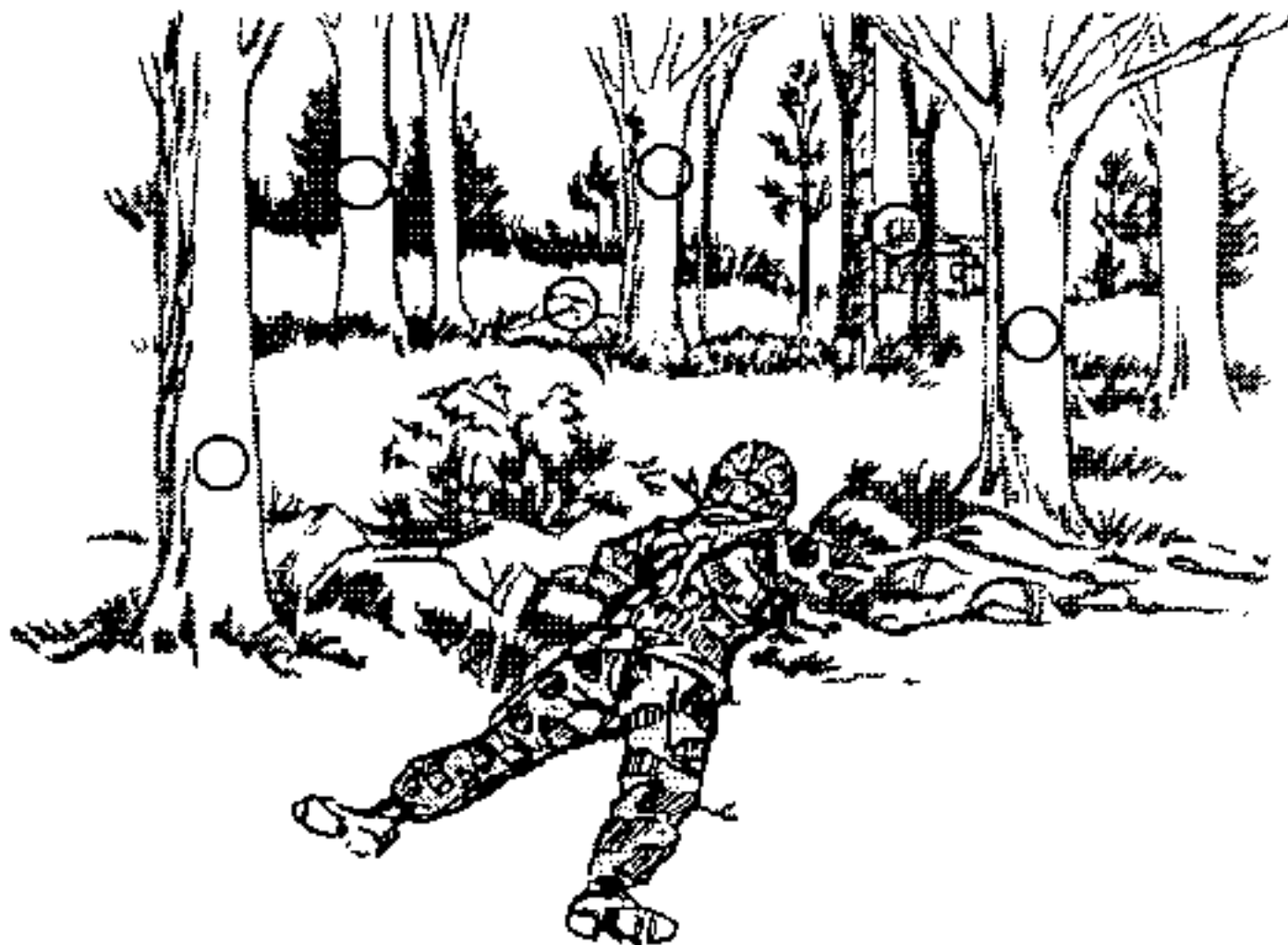

ENGAGEMENT OF TARGETS

APPENDIX F

Communications Planning and Troubleshooting

This appendix provides information and methods for communications planning and troubleshooting for the ADA sensor platoon and sections. Communications is the lifeline of the platoon leader's command and control of his sections. Sections must be able to communicate to pass EW information. FMs 24-18 and 24-24 contain further information for solving communications problems.

COMMUNICATIONS PLANNING

The number and types of communications equipment within the ADA sensor platoon vary and are dependent upon the type of unit to which the platoon is assigned. The Communications Planning Factors illustration below provides some planning factors to include distance and power requirements. Platoon leaders should pay attention to the numbers and types of batteries required to run their communications equipment.

[Figure F-1.](#)

[Figure F-1a.](#)

SINGLE-CHANNEL GROUND AND AIRBORNE RADIO SYSTEM

SINGARS is the newest family of radios in use by the US Army. The SINGARS radios make use of extensive large scale integration (LSI) circuitry, including microprocessors. A key element in the radios, the frequency synthesizer, uses new techniques to generate the required frequencies. It also provides facilities to enable the sets to operate with conventional radios. SINGARS operate in the 30- to 88-megahertz frequency range in 25-kilohertz steps for a total of 2,320 channels. It can operate in either a single-channel or frequency-hopping mode.

RADIO SET, AN/VRC-87

The AN/VRC-87 is a short-range, vehicle-mounted radio set with a solid-state, securable transceiver intended for VHF-FM tactical operations. The AN/VRC-87 is used where the communications range is normally 8 kilometers or less. The configuration is used by the ADA platoon, headquarters battery, and similar applications. The capabilities are the same as the AN/PRC-119 manpack radio, except the AN/VRC-87 cannot be used in a dismounted role. The AN/VRC-87 replaces the AN/VRC-64 radio (see the AN/VRC-87, -88 illustration).

RADIO SET, AN/VRC-88

The AN/VRC-88 is a vehicle-mounted radio that has a manpack antenna, and a battery case as additional components. The radio can be removed from the vehicle, and by installing the antenna and battery case, can be reconfigured as an AN/PRC-119 manpack radio. The AN/VRC-88 has a 4-kilometer range and may be operated from a vehicle or in a dismantled configuration. It provides more channels, reduces operator burden, and increases equipment reliability. The AN/VRC-88 is used by soldiers to communicate from vehicles or from dismantled positions. It is the replacement for the AN/GRC-160 radio (see the AN/PRC-119 Manpack Radio illustration).

RADIO SET, AN/VRC-89

The AN/VRC-89 is a vehicle-mounted, dual-configuration radio consisting of one short-range and one long-range, solid-state, securable transceiver intended for VHF-FM tactical operations. The AN/VRC-89 provides long-range (up to 35 kilometers) and short-range (up to 8 kilometers) operation in two nets simultaneously. The AN/VRC-89 is a dual-radio configuration mounted on a single vehicular mount. It replaces existing AN/VRC-47 configurations, as well as separate configurations of AN/VRC-64 or AN/VRC-46 in a single vehicle. The AN/VRC-89 is basically two vehicular-mounted, short-range radio sets with an added power amplifier that provides one of the radio sets with a long-range communications capability up to 35 kilometers (see the AN/VRC-89, -91 illustration).

[Figure F-2.](#)

[Figure F-3.](#)

[Figure F-4.](#)

RADIO SET, AN/VRC-90

The AN/VRC-90 is a long-range, vehicle-mounted radio set with a securable transceiver intended for VHF-FM tactical operations. The AN/VRC-90 is used where the communications range must normally operate over long distances (up to 35 kilometers). The AN/VRC-90 vehicular configuration is used by individuals and crews that require continuous, long-range communications in a net. The radio configuration is used throughout the Army at all echelons from corps through platoon. The AN/VRC-90 replaces the AN/VRC-46 radio (see the AN/VRC-90 Vehicle Radio illustration).

RADIO SET, AN/VRC-91

The AN/VRC-91 is a vehicle-mounted, dual-radio configuration consisting of one long-range and one short-range dismantlable, solid-state, securable transceiver intended for VHF-FM tactical operations. The AN/VRC-91 provides long-range (up to 35 kilometers) and short-range dismantlable (up to 8 kilometers) operation in two nets simultaneously. The AN/VRC-91 vehicular, long-range/short-range man-pack configuration provides maximum flexibility. The AN/VRC-91 basically combines the features of the AN/VRC-88 and AN/VRC-90 into a single-vehicle installation. The AN/VRC-91 replaces the AN/GRC-160 radio when teamed with the AN/VRC-46 in a single vehicle (see the AN/VRC-89, -91 illustration above).

RADIO SET, AN/VRC-92

The AN/VRC-92 is a vehicle-mounted, dual-radio configuration consisting of two long-range, solid-state, securable transceivers intended for VHF-FM tactical operations. The AN/VRC-92 also has an automatic retransmission capability. It is used to meet dual, long-range (up to 35 kilometers) communications requirements. The AN/VRC-92 is also used for VHF-FM retransmission operations. It is basically a AN/VRC-88 with an additional power amplifier mount to provide communications range up to 35 kilometers to the second radio system. This configuration replaces two separate AN/VRC-46 radios in a single vehicle and the AN/VRC-49 radio. Because of the automatic retransmission capability found in each SINCGARS, all AN/VRC-92 configurations are capable of automatic transmission (see the AN/VRC-92 illustration).

[Figure F-5.](#)

[Figure F-6.](#)

SINCGARS

It is anticipated that the latest version of SINCGARS will include integrated communications security (ICOMS) devices and will be fielded as soon as practical. The SINCGARS Configurations illustration illustrates the crosswalk from the AN/VRC-112 series radios and the replacement SINCGARS radios.

[Figure F-7.](#)

RADIO TROUBLESHOOTING

Moisture, dust, and corrosion are the main culprits in radio problems. Here are a few steps to try before calling the radio repairman:

- Check for water in the antenna matching unit. There is a small Phillips head screw used as a drain plug. Remove and let water drain out--allow to dry-- replace the plug.
- Check that the matching unit is matching. Move the frequency knobs at the base. They should automatically return to the proper broadcast frequency. Dust may be binding the knobs. Clean the base off. Match the frequency manually, if required.
- Check the antenna wire connection at the base. Remove the wire and clean the connections with a pencil eraser and reconnect. Be sure the radio is off for this procedure.
- Check the antenna cable for cuts.
- Check the whip antenna for breaks. Repair is covered later in this appendix.
- Check the handset and speaker connections and clean with pencil eraser, as needed.
- Check the handset and speaker connections for rubber O-rings. If not present, change headsets. Check for nicks and dry rot and replace as needed. Lubricate the O-ring with silicone or saliva on the finger and install.
- Check the vent fan at the back of the radio for dust and freedom of movement.
- Check the ground wire connection and tighten or reconnect as necessary.
- Check the seating of the radio. Pull the radio forward and check the cleanliness and straightness of the pins and plug. Reseat and secure the radio.
- If using a portable system, check the batteries and contact points. Clean as needed and or replace

the batteries.

- Do not open the case. If repairs go beyond these steps, get a repairman. Use an alternate radio or means to communicate.
- If you still cannot get through, try moving to higher ground away from power lines or obstructions.
- Try pointing the vehicle in the direction of the station to which you are sending.
- Try setting up an OE-254/GRC if you are stationary for a time.
- Set up a directional antenna to avoid being located by RDF, or if greater distance is needed. Directional field-expedient antennas are covered later in this appendix.
- If using AM, try tying the whip antenna using the tie-down cords so that the angle is approximately 45 degrees from vertical to achieve the near vertical incidence sky-wave (NVIS) antenna effect (FM 24-18).

WIRE COMMUNICATIONS TROUBLESHOOTING

The same problems that affect radios can affect the wire and telephones. WD-1/TT is very durable, but it can break down due to wear and splicing. There is no substitute for checking your equipment prior to going to the field. Try these steps:

- Have the DR-8 reels checked for conductivity. If they fail, trade them in for new ones.
- Once the hot loop has been run, check the line by hand. Look for cuts, splices, and kinks. If the distance is short, replace the line. If replacement is not practical, splice the wire according to the following illustration.
- If the ground is wet, try elevating the line overhead high enough not to cause problems.

If the wire is not the problem, telephones need to be checked. Try the following telephone checks during troubleshooting:

- Check the phone location. If the wire comes in higher than the phone, make a rain loop. The rain loop is a loop lower than the phone that allows rain to drop off prior to flowing down the line and shorting the connectors.
- Check the connections to determine if the connector is caught on the insulation.
- Check the selector switch. In most cases, the indicator should be in the local battery (LB) position. The other positions, common battery (CB) and common battery signaling (CBS) system, are normally used in garrison. Check to ensure the INT- EXT switch is in the INT position when using the handset. Use the EXT position if using the H-144/U auxiliary handset-headset.
- Check the batteries and contact points. Clean the contacts with a pencil eraser and change the batteries, as needed.
- If the temperature is low or the humidity is high, use the moisture shield supplied with the phones. These screens go over the mouthpiece on the outside of the handset.
- Check the connection of the mouthpiece. Remove the cover and check the contact points. If moist, allow to dry; if corroded, clean off with a pencil eraser and reinstall.
- If your problems go beyond this, have a technician check them out.

If using the SB/993-GT, be sure the connections are tight and that the posts are clean. Rain loops should

be used to keep moisture problems to a minimum.

[Figure F-8.](#)

FIELD-EXPEDIENT ANTENNAS

Tactical antennas sometimes break or may be rendered inoperative. It is the responsibility of the leader and his RTO to be prepared for this. The following steps and procedures help keep communications working in an effective manner.

WHIP ANTENNA REPAIR

If the whip antenna is in two separate pieces and you have both pieces, clean the areas to be connected. Use a knife to clean away insulation so that matching contact points will touch, creating a connection. Find a branch or pole to act as a supporting splint. Secure the splint to the lower section allowing about half to overhang for support of the upper section. Secure with duct tape, wire, or cord. Slip the upper portion on to the splint and be sure the connection points make contact and are secure, as you did the lower half. If the antenna is broken but not severed, shore up the broken end using a splint as above. If the upper portion of the antenna is missing, use a length of WD-1/TT equal to the length of the missing piece. Clean about 4 inches of insulation from the wire. Expose the center wire of the lower portion of the antenna. Connect the WD-1. Use a pole roughly the length of the original antenna mast. Secure the pole to the lower portion, then secure the WD-1 to the pole. The length of the antenna is critical. The antenna length should be same as the length of the antenna it is replacing.

DIRECTIONAL HALF RHOMBIC ANTENNA

Field-expedient antennas require the use of items on hand. The Insulators illustration shows some improvised insulators. The insulator is used to insulate the radiating element (main wire) of the antenna from other objects.

[Figure F-9.](#)

The length of the field-expedient antenna should be two or more wavelengths long and suspended between 3 and 20 feet off the ground. The Wavelength Calculations illustration shows the calculation of wavelength. The following is a list of materials needed to construct an antenna:

- Field wire.
- Measuring system (ruler/tape measure).
- Pole system (camouflage supports work well).
- Wire cutter/stripper.
- 600-ohm, 1-watt resistor or expedient (see the Resistors illustration).
- Ground stakes.
- Adapter UG-1441--red for radiating element and black for counterpoise (ground).

Construct the antenna according to the Half Rhombic Antenna illustration. The broadcast direction is in line with the resistor. The long-wire antenna has the same equipment list as above. Construction is shown in the Long-line Antenna illustration.

WAVELENGTH CALCULATIONS

Wavelength (in meters) = 300,000,000(meters per sec) / Frequency (hertz)

or

W (wavelength) = V (velocity) / F (frequency)

Example of calculation of wavelength for frequency: 35.95 MHz (35.95 x 1,000,000)

Wavelength = 300,000,000 / 35,950,000 = 8.34 meters

Conversion to feet: 8.34 m x 3.3 = 27.54 ft (one wave)

[Figure F-10.](#)

[Figure F-11.](#)

[Figure F-12.](#)

ALTERNATE COMMUNICATIONS TECHNIQUES

Air defense is only one of seven BOSs. Each of the BOSs have representatives down to the battalion level and all have radio communications to their own elements. Try borrowing a radio or sending quick messages or asking for assistance in relaying your message. The fire support element (FSE) has the TACFIRE system which can be used to send hard copy traffic. The drawback to this method is that it is a temporary fix and is subject to the host radio traffic requirements. If the manpower and transport are available, a messenger may be used. This is the most secure method of sending a message, but it is also the most time-consuming and may expose the messenger to hostile fire. If you are in a situation where your subelement can hear but not send and they can break squelch, instruct them to reply to yes and no questions by breaking squelch. If both stations can only break squelch, try using Morse code. The Morse code is shown in the following illustration. The drawback to Morse code is that it is a constant transmission and is time-consuming. Check the local TSOP for instructions on using smoke or sound and light signals for communications. Care must be taken not to give away your position when using these methods. The important thing is to get the message through; be as innovative as needed. It is important to have a backup communications plan in the form of alternate frequencies and TSOP procedures. This plan takes effect when communications have been lost or degraded.

[Figure F-13.](#)

COMMUNICATIONS PLANNING FACTORS

TYPE	FREQUENCY RANGE	PLANNING RANGE	OUTPUT	POWER
RADIOS				
AN/PRC 77 (FM)	30.00-52.95 MHz 53.00-75.95 MHz	8 km (5 miles)	1.5-4.0 W	EA-4386/U EA-398/U EA-5398/U
AN/GRC-163 (FM)	As Above	As Above	As Above	As Above
RT-624 (FM)	30.00-52.95 MHz 53.00-75.95 MHz	8-41 km (5-25.5 mi)	8.0-35.0 W	Vehicle FP-2959 FP-665
RT-246 (FM)	As Above	As Above	As Above	As Above
R-442 (FM)	As Above	As Above	As Above	As Above
VHF/FM RADIOS				
RT-1439 (P)/RC (VHM)/FM (NCGARS)	30.00-68.00 MHz	15-60 km (9-30 mi)	5.0-50.0 W	12 VDC 24 VDC
AN/GRC-105 (AM)	2.0-29.99 MHz	80-2400 km (50-1491 mi)	200 W	Vehicle FP-4763A
AN/GRC-213 (HF)	As Above	As Above	20 W	Vehicle 20-32 VDC

Figure F-1

COMMUNICATIONS PLANNING FACTORS (CONTINUED)

TYPE	FREQUENCY RANGE	PLANNING RANGE	OUTPUT	POWER
REMOTE CONTROL SYSTEMS				
AN/GRA-38 (FM)	300-350 Hz	Up to 2 mi WD-1/TT	N/A	12 BA-30
WIRE SYSTEMS				
SB-993/GT	N/A	22-35 km (13.7-21.8 mi)	N/A	None
TA-312/PT	300-3200 Hz	22-35 km (13.7-21.8 mi)	N/A	2 BA-30
TA-1/PT	N/A	8 km (3.7 mi)	N/A	Sound Power
TA-838/TT	N/A	3.2 km (2 mi)	N/A	4 BA-42 or 4 BA 2042

SINGLE-CHANNEL GROUND AND AIRBORNE RADIO SYSTEM

AN/VRC-87, -88

AN/VRC-87, AN/VRC-88 CABLING
CAUTION
AVOID DAMAGE TO PA: CONNECT W2 CABLE AS SHOWN.

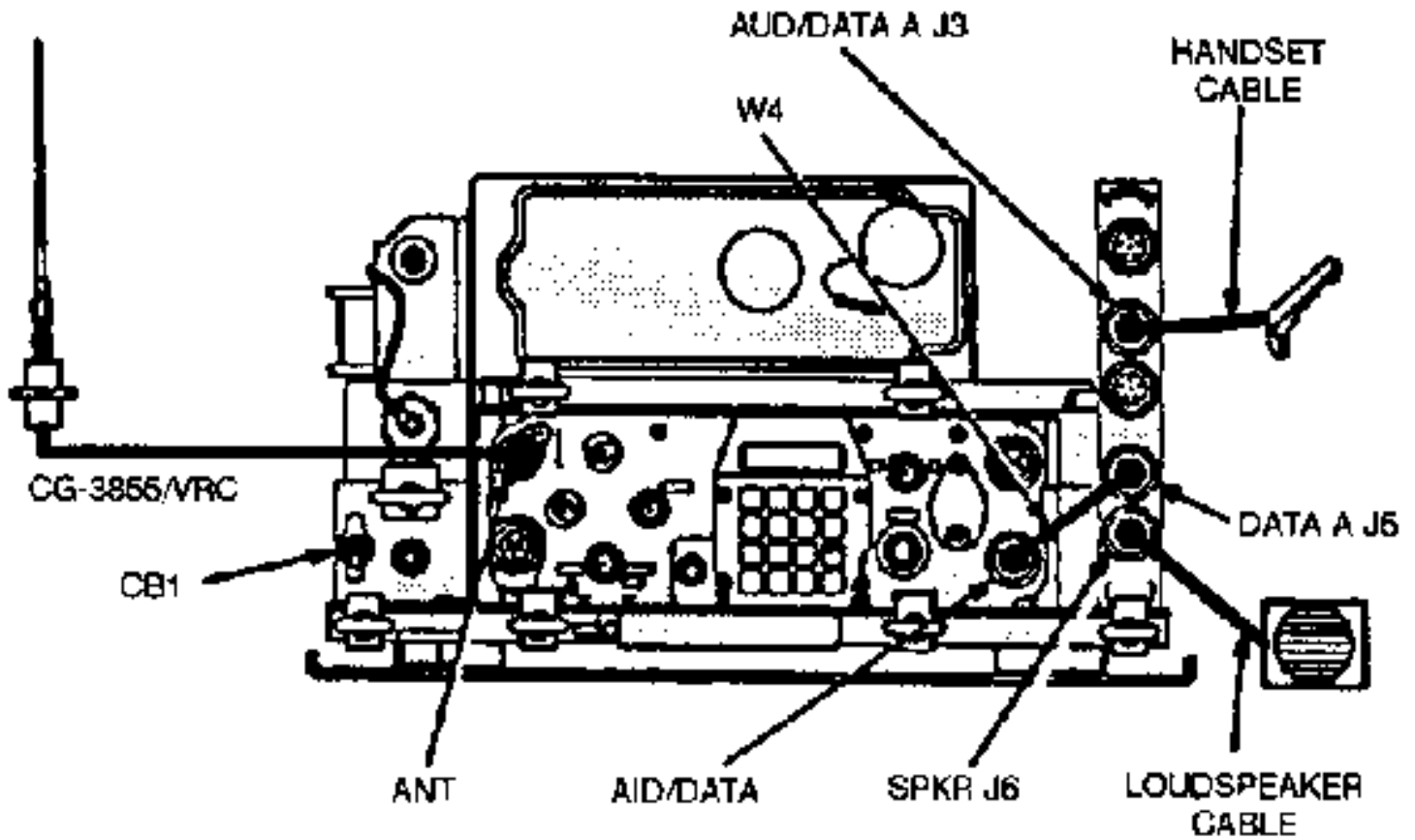

AN/PRC-119 MANPACK RADIO

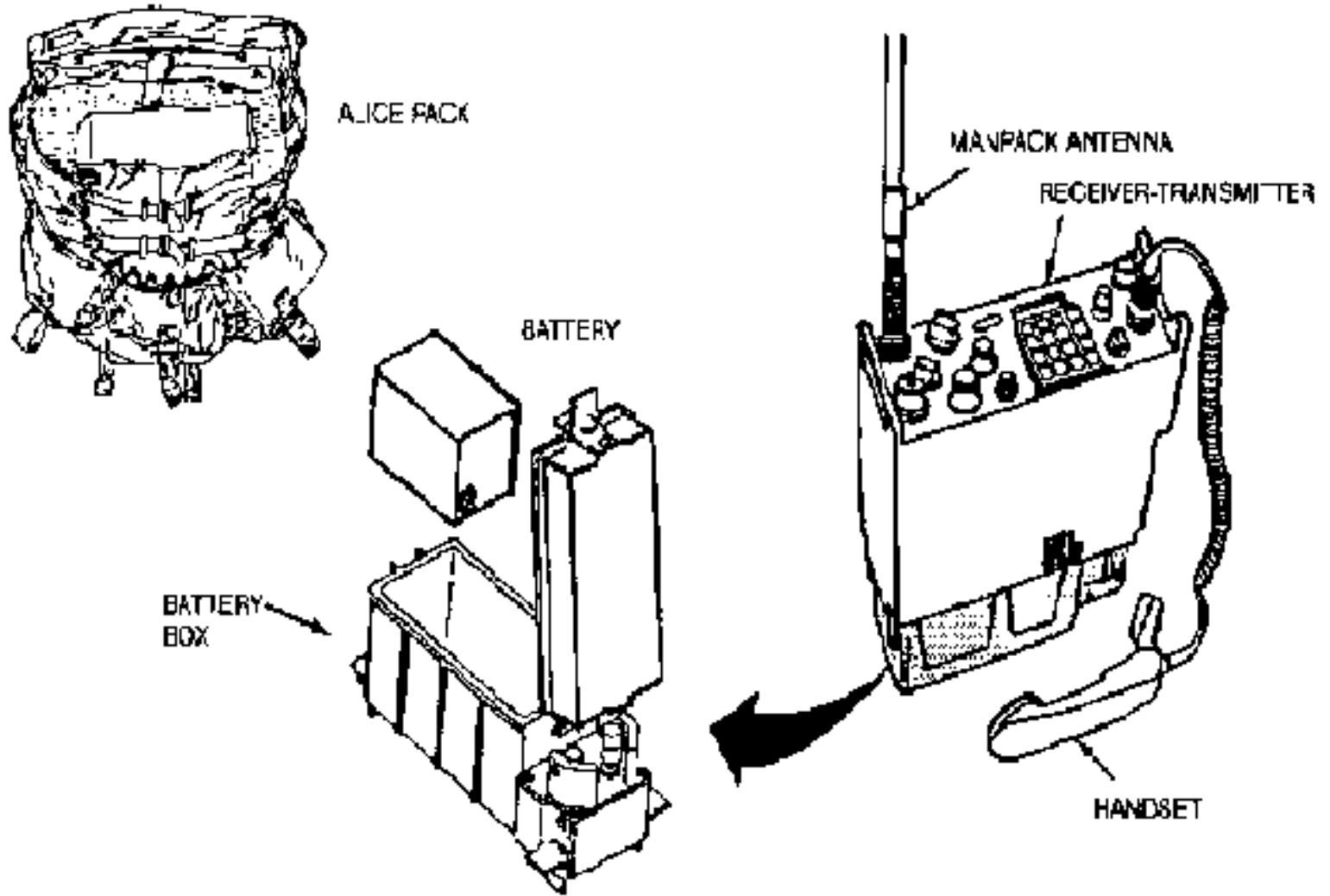

Figure F-3

AN/MRC-89, -91

AN/MRC-89, AN/MRC-91 CABLING

CAUTION

AVOID DAMAGE TO PA: CONNECT W2 CABLE AS SHOWN.

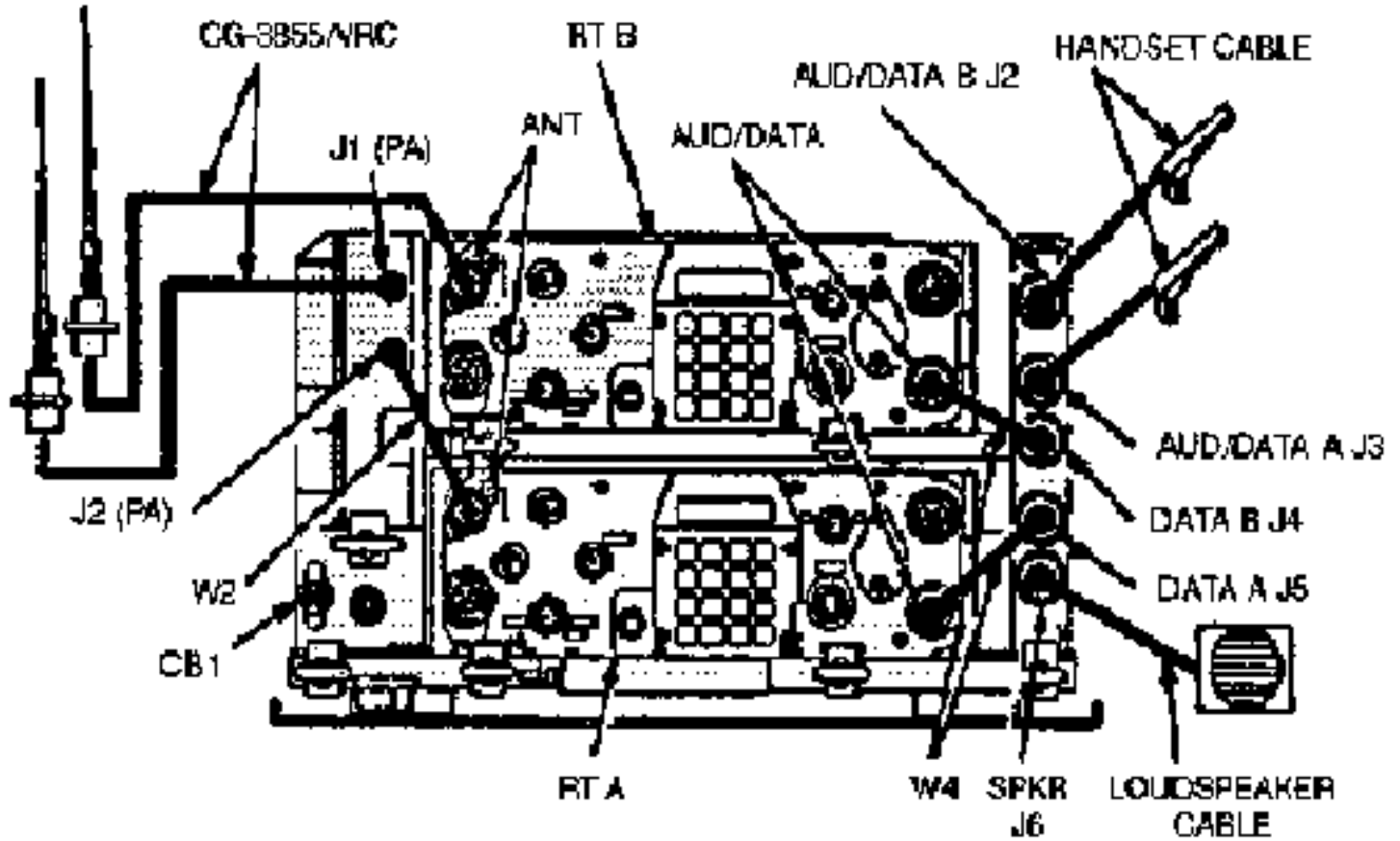

Figure F-4

AN/VRC-90 VEHICLE RADIO

AN/VRC-90 CABLING

CAUTION

AVOID DAMAGE TO PA; CONNECT W2 CABLE AS SHOWN.

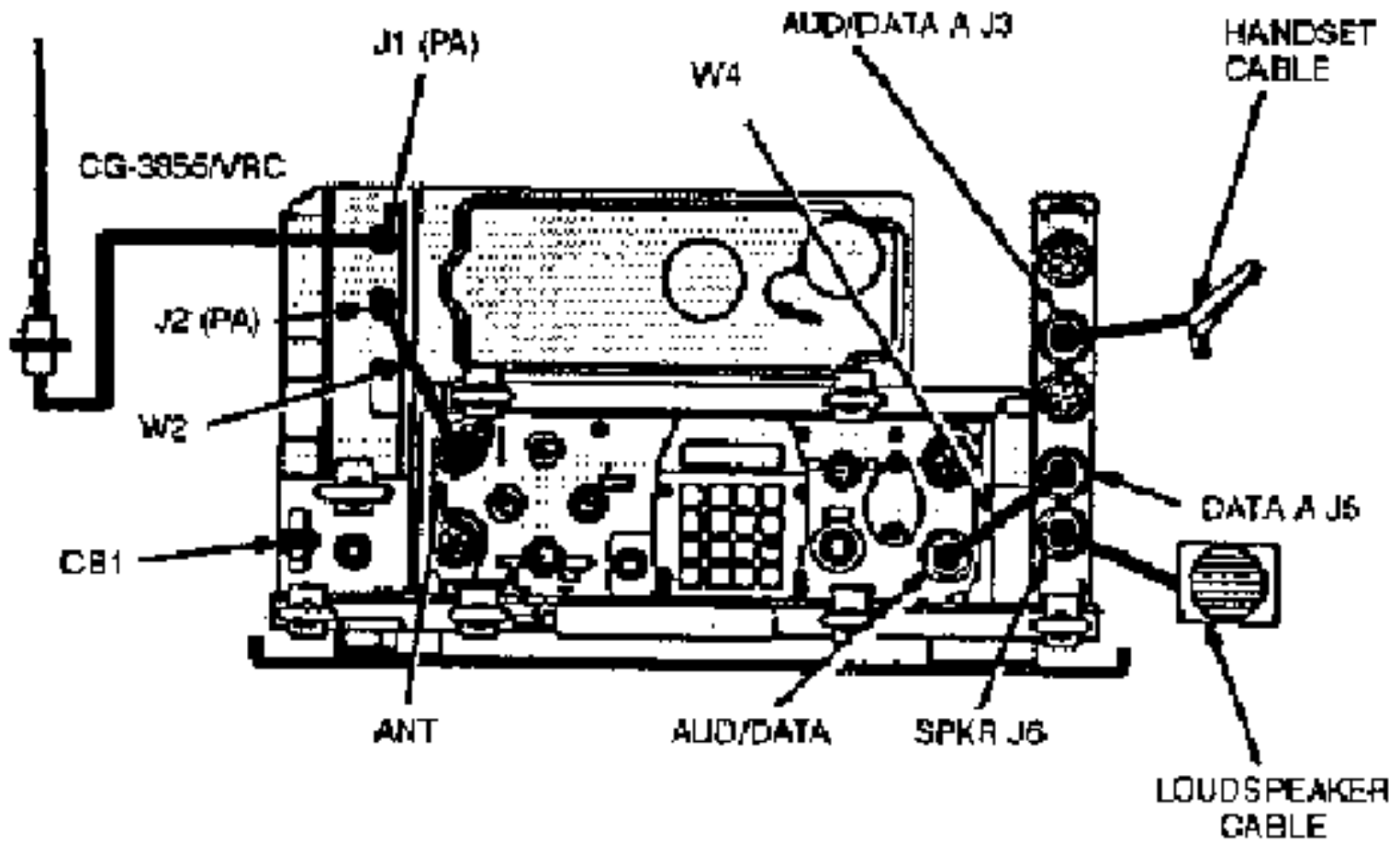

AN/VRC-92

AN/VRC-92 CABLING

CAUTION

AVOID DAMAGE TO PA: CONNECT W2 CABLE AS SHOWN.

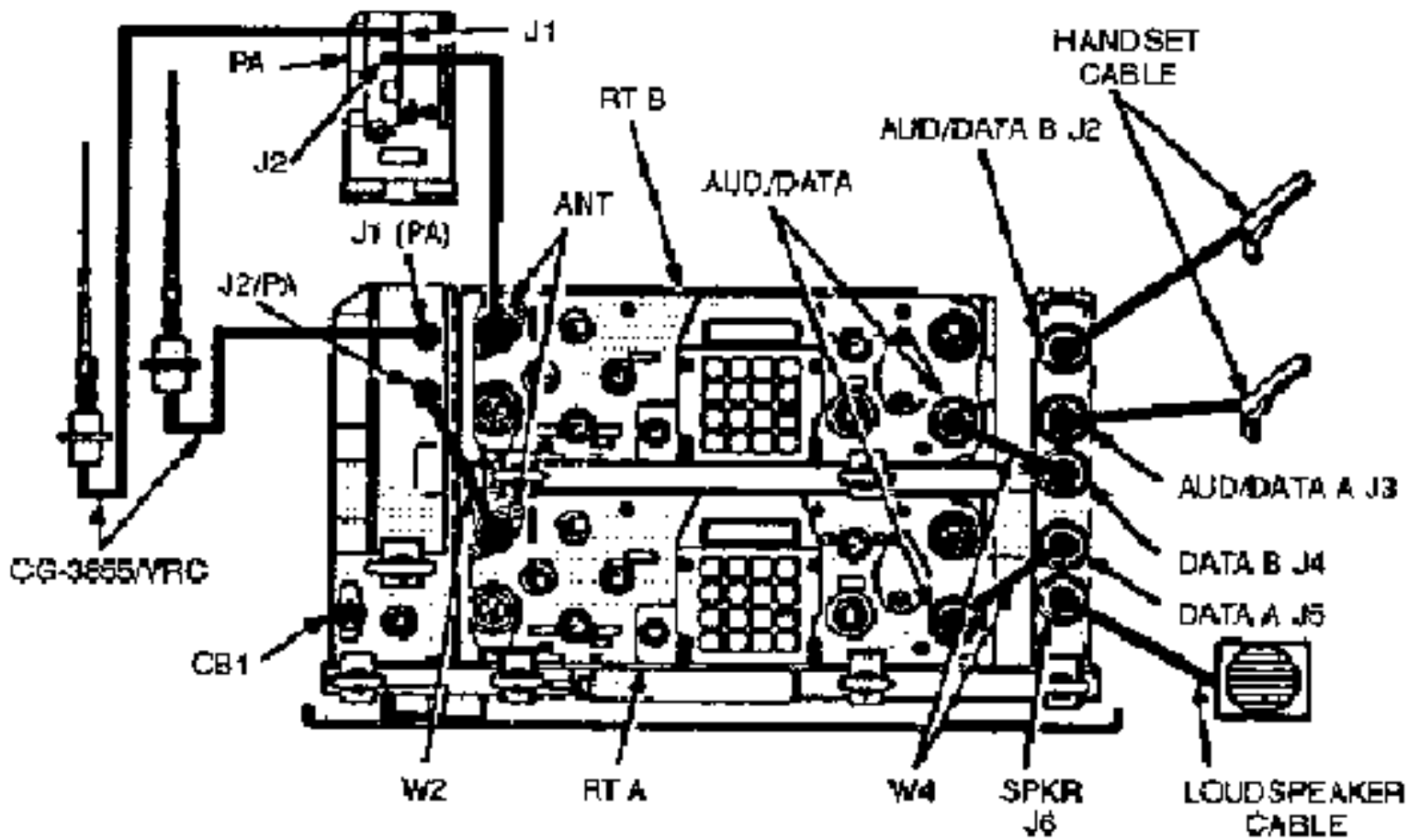

SINGARS CONFIGURATIONS

NO/NOCLATURE	FUNCTION/MSM/LIN	RT 1823 (C)/U	ADAPTER	VEHICLE ANT	MP ANT AS-3083	BATT CASE	PWR AMP	RLPLACLS
AN/PRC-119	Manpack 5820-01-287-9482/255944	1	0	0	1	1	0	AN/PRC-25 AN/PRC-77
AN/VRC-67	Vehicular Short-Range 5820-01-287-9480/255905	1	1	1	0	0	0	AN/VRC-33 AN/VRC-61
AN/VRC-88	Vehicular Short-Range Directional 5820-01-287-9481/255929	1	1	1	1	1	0	AN/VRC-125 AN/VRC-169
AN/VRC-89	Vehicular Long-Range Vehicular Short-Range 5820-01-287-9479/255913	2	1	2	0	0	1	AN/VRC-12 AN/VRC-47
AN/VRC-80	Vehicular Long-Range 5820-01-288-5105/256271	1	1	1	0	0	1	AN/VRC-43 AN/VRC-45
AN/VRC-91	Vehicular Long-Range Vehicular Short-Range Directional 5820-01-9174/256259	2	2	2	1	1	1	AN/VRC-49 AN/VRC-168
AN/VRC-92	Dual Vehicular Long-Range 5820-01-287-9177/281198	2	1	2	0	0	2	AN/VRC-45 AN/VRC-49
BB591/BB980	BH202	BF203		BB281		BF201		
ABMOC/ A702 AN/VRC-62	SENSOR CP NODE AN/VRC-63	SENSOR PLT LDR AN/VRC-61		BTBY CP AN/VRC-61 2 LAC11		PLT LDR CP AN/VRC-61 2 LAC11		
BF201	BF201	BH201		BB201		BB281/BB211		
MANPADS PLT CP AN/VRC-91 2 EACH	MANPADS SEC CP AN/VRC-88 AN/VRC-91	AVENGER FU AN/VRC-91		MANPADS FU AN/VRC-91		BTAC LNO AN/VRC-89 BDE LNO AN/VRC-01		

Figure F-7

TYPES OF SPLICES

PREPARATION OF WIRE FOR SPLICING

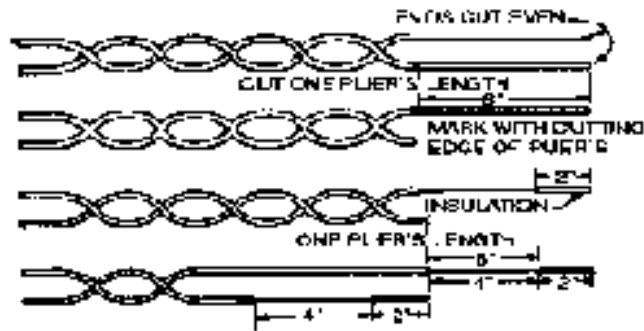

CONSTRUCTION OF THE SPLICE

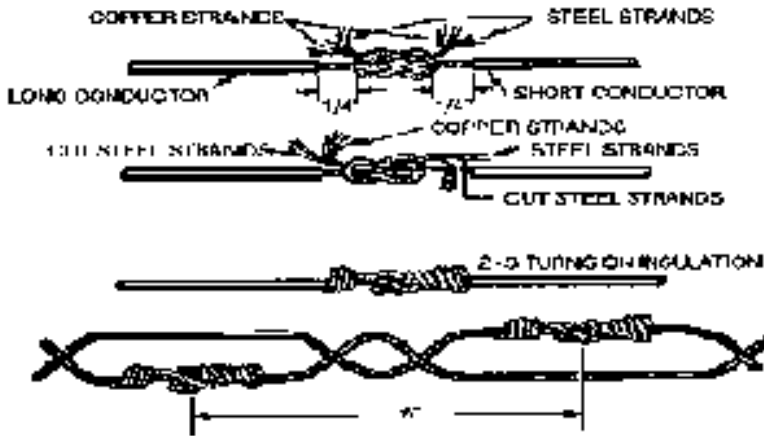

TAPING THE SPLICE

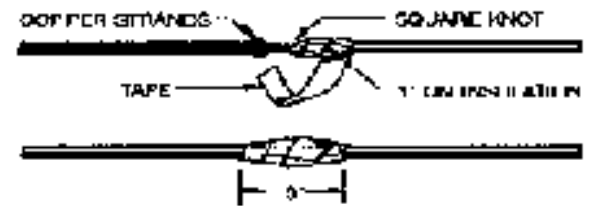

INSULATORS

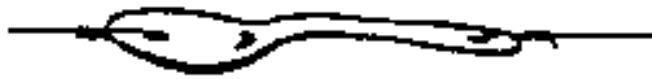

C-RATION SPOON



WOOD (DRY)



BUTTON

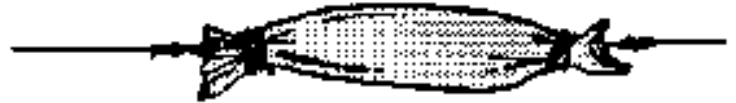

RUBBER OR CLOTH STRIP (DRY)



PLASTIC BAG



NYLON ROPE



BOTTLE NECK



NYLON ROPE

BEST: PLASTIC, GLASS GOOD: WOOD FAIR: CLOTH, ROPE

RESISTORS

TIN CAN RESISTOR (RATED APPROXIMATELY 550 OHMS)

ANTENNA LEAD

SOUP CAN FILLED
WITH SAND OR DIRT
AND SATURATED
WITH OIL



STRIPPED
LEAD WIRE

BARE LOOP

EAR PLUG CASE RESISTOR (APPROXIMATELY 550 OHMS)

STRIPPED WIRE

ANTENNA
LOAD

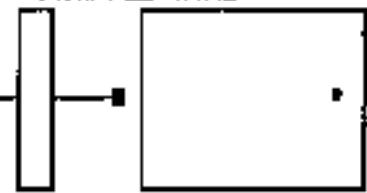

TO
INSULATOR

CASE IS FILLED WITH SAND
AND SATURATED WITH OIL

Note: The bare wires do not touch

COMMERCIAL RESISTORS

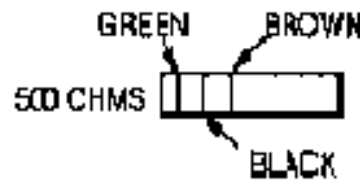

Note: The 2-watt size is 1/2 inch in diameter.

HALF RHOMBIC ANTENNA

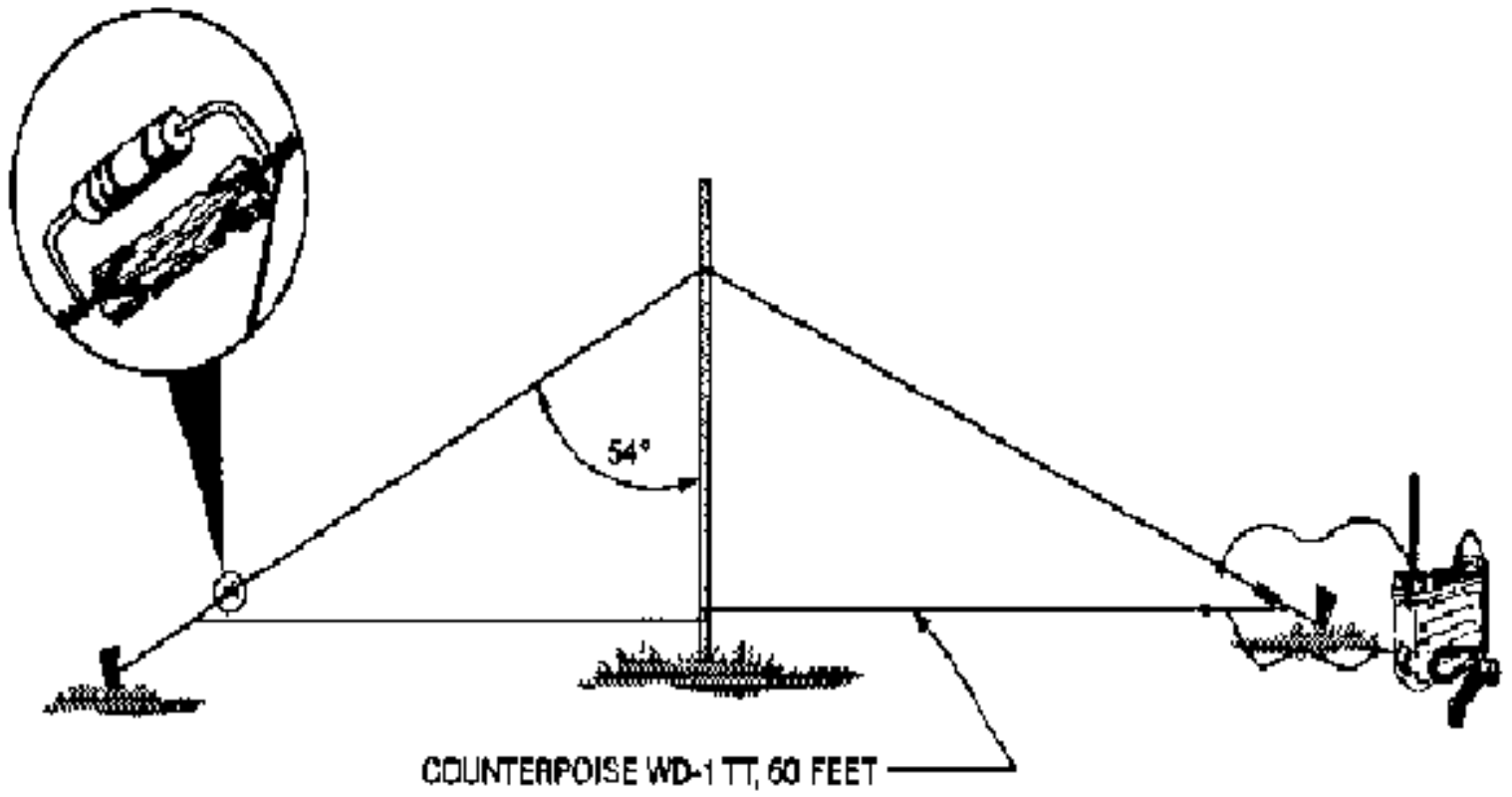

Figure F-11

LONG-LINE ANTENNA

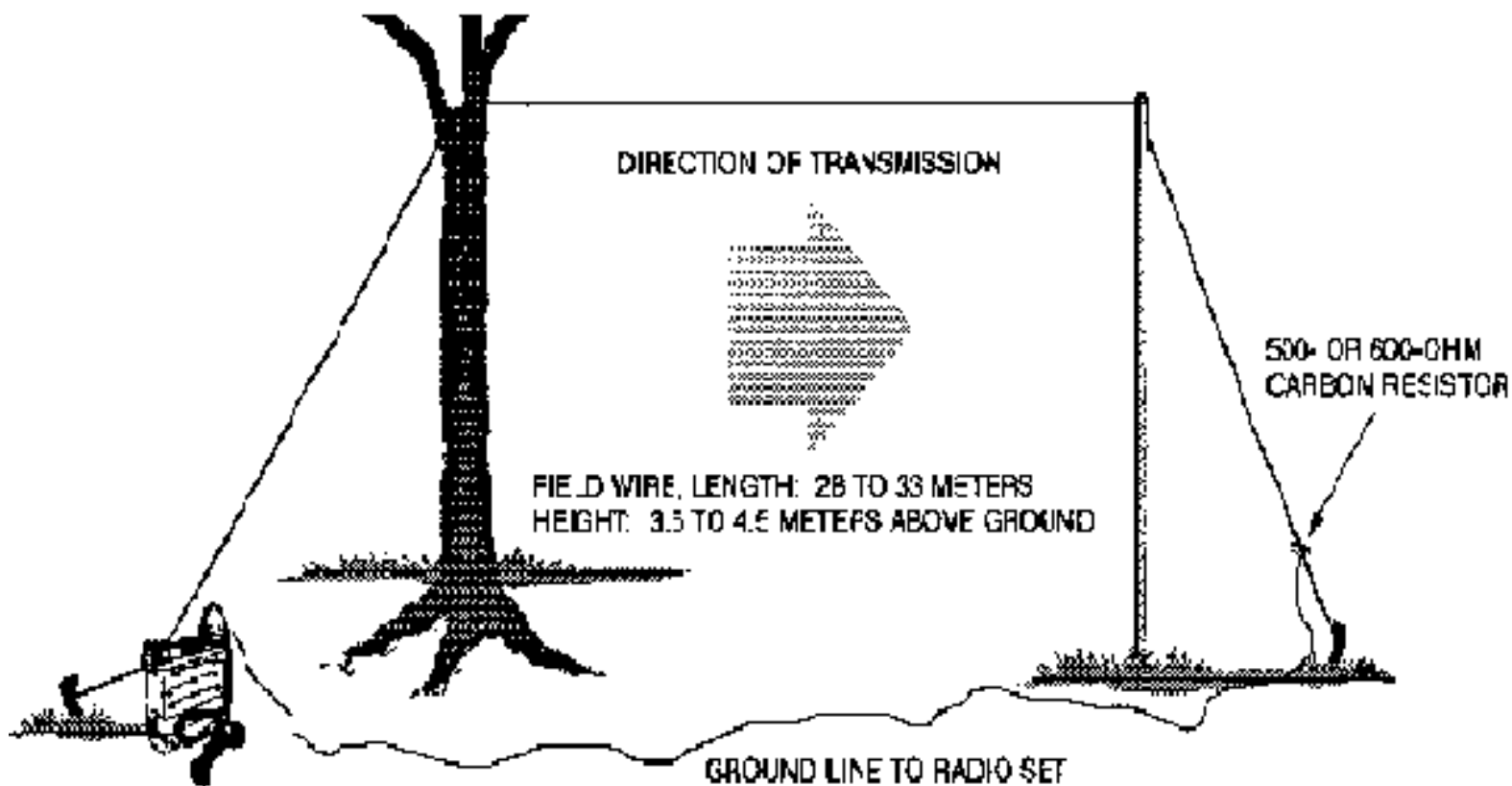

Figure F-12

MORSE CODE

A . -	M - -	Y - . - -	2 . . - - -
B - . . .	N - .	Z - - . .	3 . . . - -
C - . - .	O - - -	, - - . . - -	4 -
D - . .	P . - - .	. . - . - . -	5
E .	Q - - . -	? . . - - . .	6 -
F . . - .	R . - .	; - . - . - .	7 - - . . .
G - - .	S . . .	: - - - . . .	8 - - - . .
H	T -	' . - - - - .	9 - - - - .
I . .	U . . -	- - -	0 - - - - -
J . - - -	V . . . -	() - . - - . -	
K - . -	W . - -	_ . . - - . -	
L . - . .	X - . . -	1 . - - - -	

APPENDIX G

Sensor Employment

This appendix describes how the ADA sensor supports FAAD units during combat operations,. It covers the light and special divisions interim sensor (LSDIS) that will be fielded with all FAAD units in support of light infantry units. The mission of the supported unit is a prime factor influencing ADA employment. However, the basic mission of the ADA sensor in each employment is similar: provide time-sensitive radar alerting and tentative identification data for FAAD fire units and provide area radar coverage. This data is used to alert the air battle management operations center (ABMOC) of local air targets. It provides tentative aircraft identification. It also provides aircraft location so observers at the weapons can be cued to visually search a relatively small sector of airspace.

SENSOR DESCRIPTION

A sensor is a device that is used to detect and monitor aircraft, troops, and equipment. These devices provide information concerning locations and movements. They in turn alert and cue personnel and systems to potential targets. Sensors are typically of the following types:

- Optical.
- Infrared.
- Radar.
- Laser.
- Acoustical.
- Olfactory (chemical detection).
- Auditory.

ADA weapon systems, whether missile or gun, use sensors for the following:

- Early warning.
- Detection.
- Acquisition.
- Identification.
- Tracking.
- Surveillance.

Target information is obtained by sensors, surveillance and locating devices, and personnel. The effectiveness of countering an attack may depend on the accuracy and timeliness of this information.

EARLY WARNING

EW equipment may be integrated with weapon systems. EW is provided to operation centers and to the ADA fire units. EW is the use of sensors (human or electronic) to perform the function of providing sufficient warning of a threat attack to tactical units.

DETECTION

Detection is discovering the existence of aircraft, troops, or equipment. This discovery permits alerting and cueing of friendly forces to the presence and location

of potentially hostile forces. Enemy locations, for example, C2 facilities, radars, and enemy weapon positions, can be accurately determined by the following:

- Electronic direction-finding equipment.
- Weapons-locating radars.
- Moving target-locating radars.
- Laser range finders and designators.
- Laser target acquisition devices.
- Infrared sensors.

Refer to FMs 6-121 and 6-30 (Appendix C) for additional information.

ACQUISITION

Acquisition is the gaining of information concerning forces, both friendly and hostile, and their actions. The means of acquisition varies with each ADA system.

IDENTIFICATION

Identification of potentially hostile targets is accomplished using visual, electronic, oral, or printing devices. Identification procedures are critical to prevent fratricide. Identification, friend or foe (IFF) interrogators are used to electronically challenge aircraft transponders to determine whether aircraft are friend or unknown. Certain ADA systems use visual identification as a backup or double verification of an aircraft status.

TRACKING

The capability to track aircraft using a sensor(s) is accomplished either manually or automatically. Tracking an aircraft can involve slewing, moving the sensor, or being stationary to cover a designated area.

SURVEILLANCE

Surveillance is the watching of someone or something by using devices or humans to monitor and report on actions or operations. Surveillance is either active or passive and employs techniques proven over time to be effective to gather information concerning overt and covert operations. Surveillance sensors

provide information on activities. The information gathered is used to aid in planning, target designation, alerting, and cueing.

FAAD SENSORS

LSDIS provides ADA battalions with a sensor device meeting all-weather surveillance and detection requirements. LSDIS is the interim FAAD sensor for all light infantry ADA units. LSDIS is a lightweight, man-portable, rugged, EW sensor that provides FAAD units with cueing, alerting, and other EW information. LSDIS capabilities are as follows:

- Detects one square meter targets out to a range of 20 kilometers and from 0 to 3,000 meters above ground level.
- All weather.
- FAAD C3I/IFF compatible.
- Acquires high-speed maneuvering FW aircraft.
- Acquires hovering and pop-up helicopters up to 8 kilometers.
- Provides azimuth and range resolutions of 8 degrees or less and 1,500 meters or less, respectively.
- Provides visual display of target location in azimuth and range.
- Uses military power sources to include organic vehicle power sources.
- Two-man emplacement or march order.
- Operable by one man.
- Airdroppable or parachutable and transportable by medium helicopters and HMMWVs. The LSDIS platoon will be assigned to the headquarters and headquarters battery (HHB) of the FAAD battalion. The platoon will have six LSDIS for deployment. The LSDIS section consists of three crew members: a section chief, a sensor operator, and an operator/driver. The current employment concept requires that the LSDIS be transported by the HMMWV.

RECONNAISSANCE AND SURVEILLANCE PLAN

A platoon of six sensor sections is organic to the FAAD battalion. These sections are deployed in support of the Bradley Stinger Fighting Vehicle (BSFV), Chaparral, Avenger, and Stinger fire units to provide EW and assist the engagement process.

The ADA battalion S2 develops the reconnaissance and surveillance (R&S) plan as part of the division R&S plan. The S3 and S2 determine the best positions for sensor employment per the IPB to cover NAIs and TAIs. The S3 controls the sensors to cover NAIs and the S2 has staff responsibility for integrating the use of the battalion's organic sensors into the division R&S plan. He coordinates with the ADA battalion S2 in the development of the battalion's R&S plan. The S3 prioritizes sensor employment and coordinates for the usage of terrain. The R&S plan is modified as the tactical situation dictates. The plan includes specific guidance for the deployment and operation of the sensors as well as organic weapon system sensors. Battery commanders, having two sensors allocated to their unit for support, have use of and positioning authority over those sensors under the guidance provided by the battalion R&S plan. Close coordination between battery commanders and the battalion S3 is required to ensure that overall sensor coverage is obtained.

DEPLOYMENT METHODS

Sensors are normally deployed under ADA battalion control to provide coordinated area coverage per the battalion R&S plan. However, sensors may be attached to or placed under the operational control of a firing battery commander to better fit or support the maneuver scheme. When employed in this manner, at least two sensors should be allocated to a battery. This will afford a continuous coverage capability. One of the sensors can remain in position while the other displaces (METT-T dependent). The ADA battalion commander must consider certain deployment factors to determine which method to use. These factors include, but are not limited to--

- Deployment of supported forces.
- Deployment of fire units.
- The enemy threat, both air and ground.
- Terrain: level, hills, valleys, water, et cetera.
- Electronic warfare environment.

The methods of employment are as follows:

- Method A. The sensor sections are deployed by the sensor platoon leader with staff supervision exercised by the ADA battalion S2 per the DST and DSM. The S3 coordinates the selected map positions with the division A2C2 cell. In this method, the platoon leader retains control of the sections.
- Method B. Two sensor sections are allocated to each firing battery. The firing battery recommends sensor positions to the ABMCC OIC. The S3 coordinates these positions with the ADA battalion S2 and division A2C2 cell. The S3 recommends approval or changes them, and forwards the approved positions to the firing battery commander.
- Method C. Two sensor sections could be attached to a firing battery, as in Method B. The rest of the sensor sections remain under the sensor platoon leader as in Method A.

Other variations are also possible (METT-T dependent).

EMPLOYMENT GUIDELINES

The six sensors organic to the FAAD battalion are employed to provide data to ADA fire units in the battalion. This is accomplished by providing coverage of the low-altitude approaches to the division with priority to the front, followed by the flank and rear areas. The most forward sensors are placed close to the FEBA (within 2 to 5 kilometers) to provide timely early warning information. These forward sensors should be emplaced to receive protection from observation by use of light foliage, camouflage, and cover. Displacement, coordinated with the controlling authority, may be used to enhance survivability of the sensors, particularly those deployed well forward. The six sensors are not enough to provide coverage to an entire division area. The ADA battalion S2 must carefully integrate the sensors into the division R&S plan according to the DST and DSM and the aerial portion of the IPB. He should concentrate on covering critical NAIs, TAIs, and AAAs. Sensors should be employed no more than 10 to 15 kilometers apart. This will provide mutual support and overlapping coverage and will minimize no observation zones (dead spaces) caused by terrain masking. See the illustration on page G-4. Sensors are displaced to provide continual coverage of tactical operations. They also displace

on the initiative of the section chief when the receipt of direct or indirect fire indicates imminent destruction. The sensors will transmit according to the R&S plan. Blinking is not necessary unless the sensors are in position over 30 minutes (METT-T dependent). When sensors are employed in pairs (encouraged) they are emplaced not less than 2 kilometers apart to reduce interference to each other. This also increases the difficulty of locating them by enemy direction finders. See the Sensor Employment by Pairs illustration. Position selection for the sensor sections is critical to the timely transmission of EW information to the fire units. Equally important is EW coverage of the defended area. Final selection of positions for each sensor must be coordinated with the battalion S3. Positions selected must provide coverage throughout the area in which the weapons are employed. Sensor sections will--

- Pass alert data to the ABMOC in time for effective reaction by fire units to the air threat. To meet this requirement, radar coverage should extend beyond the unit positions at least 10 kilometers in the expected direction of air attack.
- Provide continuous alert warning. Move to support operations.
- Position not more than 10 to 15 kilometers apart for mutual radar coverage.
- Provide security from small arms and automatic weapons fire. When possible, the most forward radars should be employed in secure areas no closer than 2 to 5 kilometers to the FEBA or line of contact.

OPERATIONAL CONSIDERATIONS

Sensor positions must provide alerting data in time to ensure effective reaction to the air threat. This requirement is met by ensuring that sensor coverage extends beyond the fire unit's position in the expected direction of attack. Individual section sites are chosen to obtain maximum low-altitude radar coverage of a designated area. Sites are also selected to provide radio line of sight (LOS) to the ABMOC and the maximum number of in-range fire units. Since the sensor will be an attractive target for air attack, consideration should be given to collocating the sensor with a fire unit, whenever position and mission requirements permit. Whenever possible, it should be located within the defense perimeter of ground security forces.

SURVIVABILITY

ADA missiles, automatic weapons, and radar units are lucrative targets for ground and air attack and usually are employed in secured areas. ADA survivability against enemy air and ground attack can often be improved by locating weapons and sensors as deep in friendly territory as possible. The location must provide the ability to perform the assigned mission without degradation.

[Figure G-1.](#)

[Figure G-2.](#)

AVOID DETECTION

Actions to improve battlefield survival include--

- Selecting a position that is hidden from enemy ground observation.

- Moving during darkness.
- Taking advantage of terrain to provide cover and concealment for the radar.
- Blending equipment into natural background.
- Erasing or covering tracks.
- Keeping positions litter-free.
- Enforcing noise and light discipline.
- Maintaining radio silence when possible; continuously practicing communications security.
- Exercising emission control orders (EMCONs) (for example, limiting number of operating radars and frequency management).
- Using camouflage netting, pattern painting, and natural material to camouflage the position.

MOVE

One of the best ways to keep the enemy confused concerning the location of a sensor is to move often. When changing positions, it is not necessary to move a great distance. A move of 500 meters may be enough. Alternate positions are selected within a short distance from the primary position and occupied as required. The move should be as rapid as possible so that the section is again ready to detect enemy targets. Things to consider in regard to movement are--

- Move often to keep the enemy from targeting the position.
- Move a short distance.
- Move at night or when visibility is limited.
- Move quickly--get back in operation.

Consider moving after recent air reconnaissance of the area, the position has been fired upon, or when the system has radiated from the same location, continuously or intermittently, for two hours or more.

FORTIFY POSITIONS

Use of field fortifications reduces damage to materiel and injury to section members when, despite other countersuppression measures, enemy forces locate and attack a sensor site. Two restrictions make it difficult for the section to construct adequate fortifications. One is the limited number of personnel to do the work. The other is the comparatively short time the section usually remains in the position. However, sections fortify each position to the extent possible. Fortifications are started as soon as practical upon arrival in a new position.

To make fortifications easier, select positions that are out of sight of enemy ground observation (for example, the reverse slope of a hill rather than its crest). The same barrier to enemy observation also provides a barrier to enemy direct fires. A patch of woods can provide concealment. Camouflage prevents pointing out the position. Field fortifications should complement camouflage, not degrade it. Look for areas that provide natural protection. Terrain irregularities (such as defilades or mounds) provide initial fortifications. These can easily be completed with sandbags or other fortifying materials. Engineer assistance may be available to aid in construction of protective positions and employment of camouflage and decoys. See the following illustration.

[Figure G-3.](#)

SENSORS WITH MUTUAL SUPPORT

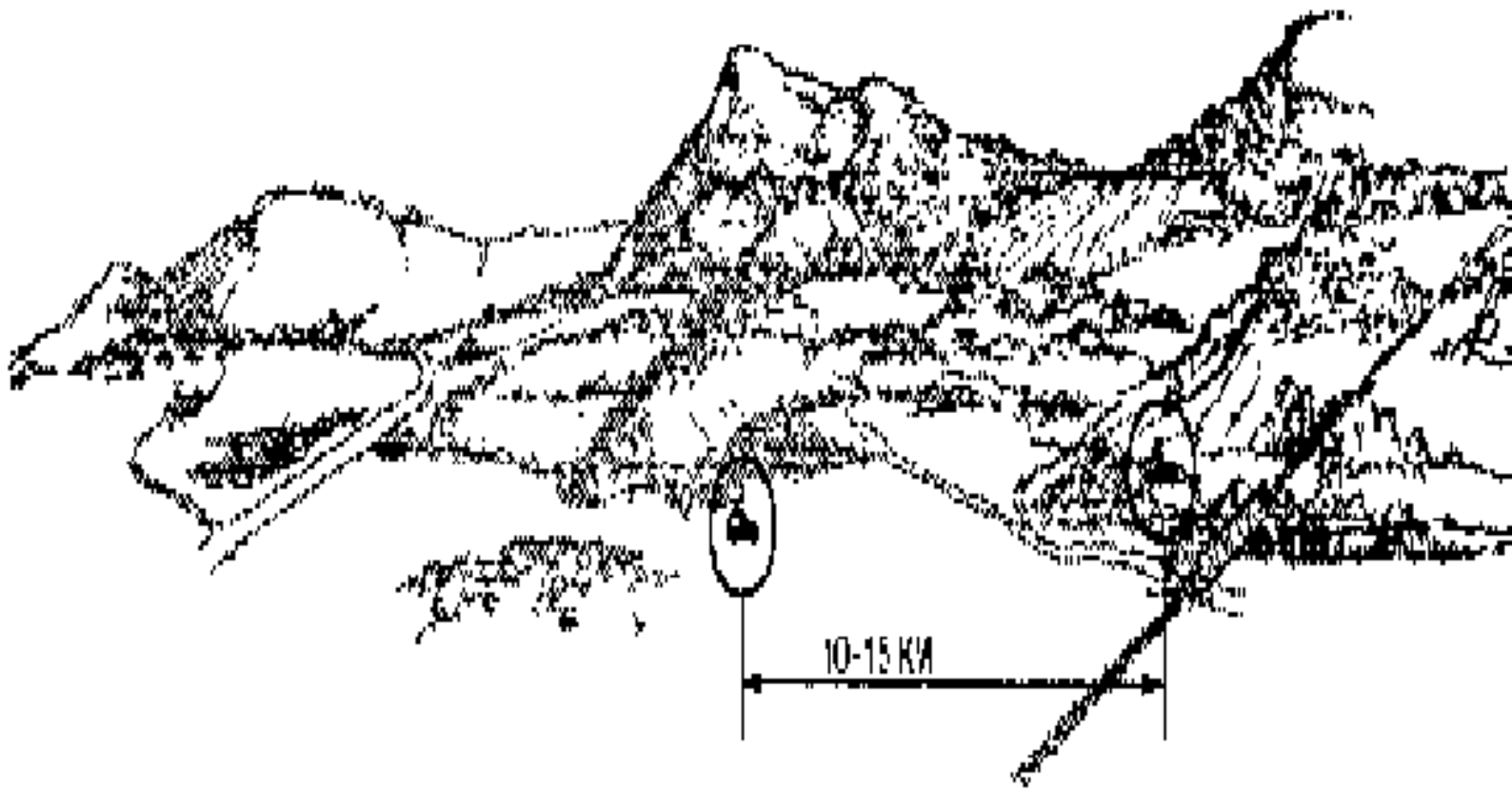

Figure G-1

SENSOR EMPLOYMENT BY PAIRS

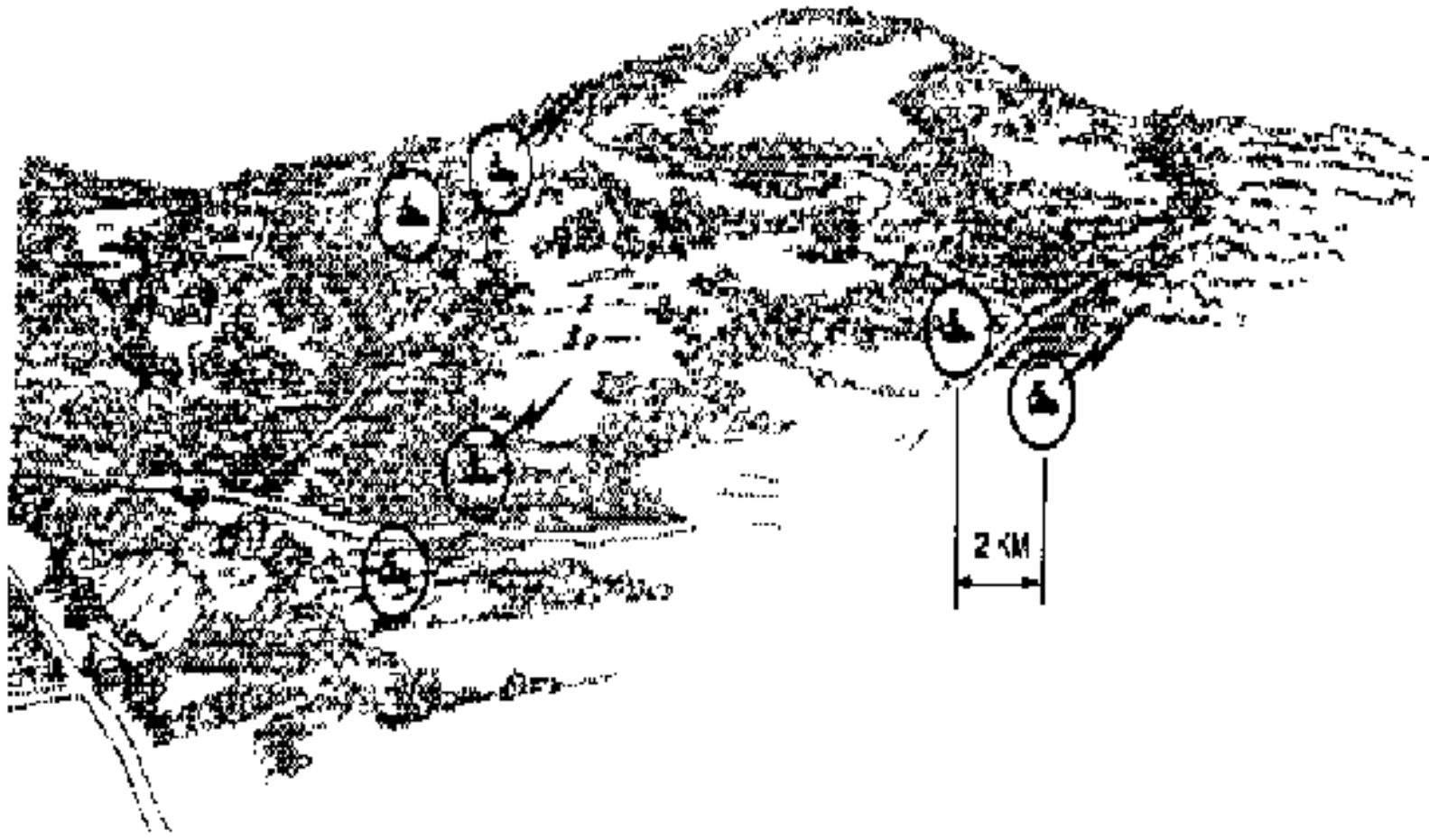

Figure G-2

HIDING A SENSOR USING NATURAL COVER AND CONCEALMENT



Figure G-3

APPENDIX H

Manual SHORAD Control System

This appendix provides standardized procedures for the manual SHORAD control system (MSCS). The objectives of the MSCS are to provide near real-time transmission of EW information to FAAD and other divisional units and weapons control information to the FAAD unit organic to the division. It also integrates ADA data into the division airspace management effort. EW data is available to any unit which is capable of receiving it. This includes ADA units, the divisional maneuver units, and combat support or combat service support units. ADA fire units (FUs) are more effective if they are provided accurate, timely, and reliable EW. EW serves two purposes--alerting and cueing. Alerting information tells the user that an aircraft is approaching his position or the assets he is defending. Cueing information tells the user from which direction the aircraft will be coming, its positional location, and its tentative identification in a timely manner. This enables the user to focus his attention in that direction to detect the aircraft at a greater range. To obtain this information, FAAD units use a manual control system that provides alerting, but very limited cueing.

MSCS NETS AND COMPONENTS

The MSCS uses various communications nets and components to provide timely, accurate, and reliable EW information. The MSCS is implemented through three communications nets. The air defense coordination net (ADCN) provides EW information to the FAAD battalion from HIMAD systems or Air Force sources. It also facilitates command and control with those who monitor the ADCN. The division early warning (DEW) net disseminates a standardized form of manual EW within the division MSCS. The sensor net is used to pass those air tracks that are in the LSDIS 20-kilometer alert threshold, to the ABMOC/BNTOC, which will be correlated with the nearest HIMAD source and distributed to its customers, that is, battery, platoons, section and FUs, and associated maneuver elements. A nearby element within LOS can monitor the sensor net if so desired.

AIR DEFENSE COORDINATION NET (AM)

This net is used to transmit long-range track information, weapons control information, and facilitate command and control to the FAAD battalion TOC by communicating with the following sources:

- Brigade TOC LNOs (maneuver).
- Sensor platoon leader/sensors.
- Division TAC CP LNO.
- Local HIMAD source.
- ABMOC.

- ADCOORD officer.
- A2C2.

Long-range track information can be obtained at a HIMAD (Hawk or Patriot) fire direction center (FDC) or Air Force forward air control post (FACP), control and reporting post (CRP), or control and reporting center (CRC). The net control station (NCS) for the ADCN is the FAAD battalion air defense fire coordination section (ADFCS).

DIVISION EARLY WARNING NET

The DEW net is a one-way FM net originating at the FAAD battalion ABMOC. Any unit with an FM receiver and within line of sight (LOS) and operating range restrictions can obtain EW (MSCS) information simply by monitoring this net. Units unable to receive this information due to the restrictions mentioned above can obtain early warning from adjacent, subordinate, or parent units that are receiving the information. See the illustration below.

SENSOR NET

EW fixed- and rotary-wing information transmitted by the sensor, using MSCS, is received at the FAAD ABMOC/BNTOC in MSCS format. The FAAD ABMOC/BNTOC, in turn, correlates this information with the nearest HIMAD long-range EW information source. It distributes it in MSCS format to its batteries, and those maneuver elements that the FAAD battalion is supporting. Also, this net can be monitored by any element if so desired. Command nets, while not strictly part of the EW system, contribute to the efficient EW functioning of the system. Command nets contribute to the EW system by providing a backup communications network for directed EW.

COMPONENTS

The MSCS uses a unique grid system. A standard grid matrix is used with a specified reference point. The map coordinates of this reference point will normally be designated in the AD annex of the division operation order as will be the map sheet series number. The location of the reference points is standard on each sheet; however, it may be moved for security reasons. This can be accomplished by designating another intersection as the reference point (for example, intersection of HEMLOCK, INSECT, HAZEL, and INDIAN) and applying the specific map coordinates.

Early Warning Grid Matrix

The EW grid matrix is a standardized matrix consisting of 400 grid squares with a code name assigned to each square. Users need only use that portion of the matrix applicable to their areas of operation. The matrix reference point should be set to extend the matrix coverage at least 20 kilometers beyond the division boundaries. See the Early Warning Grid System Matrix illustration.

[Figure H-1.](#)

[Figure H-2.](#)

Standard Track Format

The sensor operator uses the standard report format to relay target information. The following illustrations are examples of a track report format and a FAAD grid example within a division area.

TRACK REPORT FORMAT

PREFACE Initial track (repeat twice), track update, scrub track, or mass track.

ID Friend, unknown, or hostile (friendly, not normally transmitted).

LOCATION Lemon, 3-3 (10-km grid square designator plus 1-km grid increments for easting and northing read to the right and up).

HEADING Southwest, north, et cetera.

RAID SIZE One, few (2-4), or many (more than 4 - only used for mass tracks).

AIRCRAFT TYPE Jet, prop, or hel.

TRACK DESIGNATOR A-O assigned by detecting unit.

[Figure H-3.](#)

The Track Plotting illustration shows an example of an initial track, a mass track, and a track update. The initial track, track update, track update identified, scrub track, and mass track are described in the Track Report Examples illustration.

[Figure H-4.](#)

[Figure H-5.](#)

AIR DEFENSE FIRE COORDINATION SECTION

Trained personnel must understand both the structure and procedures of the MSCS for it to function smoothly. The following paragraphs discuss how the MSCS operates, who performs the functions at each level, and finally, how it is used. ADFCS usually consists of 10 to 15 personnel, then is broken down to accommodate individual sections (officer and driver minimum) which is called the air defense liaison officer (ADLNO) and a driver radiotelephone operator (RATELO). During operations, the sections deploy to the maneuver brigades, DTAC, and the nearest HIMAD or Air Force source to furnish long-range track information. Once deployed, the ADFCS establishes two-way AM radio communications with the ABMOC. See the illustration below. The ADFCS passes long-range aircraft track information and AD command and control information (for example, air defense warnings and weapons control status) disseminated through HIMAD and USAF control systems to the ABMOC over this net. The ADFCS obtains HIMAD track information by physically viewing a radar console or having the console operator do the interpreting of EW tracks. This provides the most timely EW information. The console can either be a fire unit or control facility radar scope on which the division's air picture is displayed. In situations where it is impossible for the ADLNO to physically view a radar scope, adequate data can be obtained from a manual plotting board. As with the radar console method, the division's area of operations should be marked on the plotting board. See the ADLNO Clipboard Map With FAAD Grid illustration. EW track data is passed in FAAD units in the following ways:

- When the ADLNO places his GEOREF acetate overlay over the FAAD grid on his clipboard, he can convert the GEOREF position to a FAAD grid position.
- If the ADFCS has an AN/GRA-6 radio set control group (AM remote unit), the ADLNO can transmit directly from the HIMAD source to the ABMOC.
- If the ADFCS has no AN/GRA-6 radio control group, it may use two TA-312/PT telephones. Using a TA-312/PT, the ADLNO can relay the track report to his driver/RATELO, who transmits the report on the AN/GRC-193.

[Figure H-6.](#)

[Figure H-7.](#)

The NCS for the ADCN is the ADFCS. The ADFCS uses the ADCN to transmit track reports to the FAAD TOC. Located where he can view a radar console or manual plotting board, the ADLNO detects tracks located within or approaching the division's area of operations. He converts track GEOREF positions to FAAD grid positions and transmits track EW to FAAD TOC. Position data is transmitted via a standardized format either directly or through the ADFCS driver/ RATELO. The ADLNO also acquires and transmits AD command and control information to the FAAD TOC. See the ADLNO Conversion of GEOREF Position illustration.

FAAD BATTALION ABMOC/TOC

FAAD ABMOC personnel receive and filter the ADFCS track report. They record the track, determine if the track requires retransmission (filtering), and transmit EW over the DEW broadcast net. Air defense warnings and other AD command and control information are also transmitted over the battalion net, the DEW broadcast net, or the sensor net.

USING UNITS AND EQUIPMENT

To be of best use to FAAD units, EW information must be displayed. Personnel must know how to use plotting equipment to display the information.

FAAD

Directed EW over the command net is the preferred method of passing EW to fire unit level. For BSFV, Avenger, and Chaparral units, plotting is done by an observer located with the squad leader. For Stinger teams, plotting is done by the team chief. This information is used to alert personnel of aircraft in their vicinity. Command and control information received over the sensor EW net may require authentication and acknowledgment. This would be accomplished over command nets.

[Figure H-8.](#)

NON-ADA UNITS

These units may monitor the DEW broadcast net or the sensor net for EW by using the FAAD grid. They may also receive this information through liaison from supporting ADA units.

PLOTING EQUIPMENT

The MSCS map/plotting case is a canvas and plastic map case adapted for use as a plotting board for the FAAD fire unit. The plotting case consists of a 30-by 30-kilometer plotting grid; a copy of the 200- by 200 kilometer standardized FAAD grid system; a status board, a pen, pencil, and rag storage compartment; and operating instructions. The MSCS map/ plotting case is shown in the following illustration. To set up the map/plotting case for operation, the following steps must be accomplished:

- Orient the map case to magnetic north.
- Find position on the map.
- Place the map under the plastic grid with position in the center grid box.
- Align the 10-kilometer major grid lines with the grid printed on the plastic. Keep position in the center grid box.
- Write the appropriate grid names on the plastic.
- Mark position on the plastic.
- Mark PTL on the plastic.
- Draw a clock around position (12 o'clock is on the PTL and 6 o'clock is to the rear).

Once the map/plotting case is set up as described, you are ready to plot per plotting instructions described earlier in this appendix (see the Map/Plotting Case illustration).

[Figure H-9.](#)

ALTERNATE MSCS PROCEDURES

Alternate routes for command and control information are provided for in the MSCS; these include the DEW broadcast net and command nets. In the event of loss of communications in the MSCS, procedures are flexible enough to make maximum effective use of remaining command and control facilities. For example, weapons control statuses, hostile criteria, and emergency information received from the ADLNO, division TOC, and or the brigade TOC can be passed to FAAD units via the DEW broadcast net or via the FAAD battalion command net. Emergency information is information that must be disseminated rapidly throughout the division, such as NBC strike warnings and enemy airmobile assaults. The division G3 and G2 are normally the primary sources of this information, which is usually disseminated through the division intelligence net and relayed down command nets. The DEW broadcast net provides the means to rapidly disseminate this information throughout the FAAD battalion. Alternately, the command nets are used to disseminate emergency messages and critical warning information.

LSDIS USING MSCS

Upon energizing the control indicator unit (CIU) the operator has the choice of selecting two forms of display on the plan position indicator (PPI). Either a range ring display or FAAD grid display can be selected to aid in target location. To use MSCS, the operator selects the FAAD grid display (see the PPI FAAD Grid Display illustration). With the FAAD grid display, the operator conducts manual plot and reporting of air targets. A common reference point is used as designated in the AD annex of the OPORD.

The grid matrix displayed on the PPI is a 10- by 10-kilometer box with 1-kilometer increments. The names on the grid are filled in by the operator. The display grids correspond to grids on the EW grid system matrix.

The FAAD grid matrix is a standardized matrix consisting of 400 grid squares with a code name assigned to each square. The operator uses only the portion of the matrix needed for his operation. The scale of the grids on the PPI display is the same as on a 1:250,000 map. To achieve the designed accuracy, the sensor operator must know the actual position of the sensor. He obtains the sensor's location in relationship to the MSCS map. To set the PPI grid display for operation, the sensor operator should perform the following procedures. With the center of the grid display as the sensor's position, position the grid display as follows:

- At the CIU keyboard, use the arrow keys to position a 10-kilometer grid over the PPI center so that the centered cursor "X" symbol appears at the coordinates determined on the MSCS map.
- Once the grid is positioned, press "enter" for the grid to stay in position and the arrow keys to be used for cursor movement.
- Write the appropriate grid names of all grid squares on the display.

Using china markers (grease pencils), the sensor operator manually plots detected aircraft on the PPI display. Air targets are also plotted on the MSCS plotting/map case and MSCS map available to the operator. This additional platoon information provides the operator with a general view of the division air picture. It also provides direction of an aircraft that could enter the sensor's area of coverage.

TARGET IDENTIFICATION

The following four unique symbols are used to display unknown targets (those with no IFF response) and friendly targets (those with IFF response), and to discriminate helicopter targets from fixed-wing targets:

- Unknown rotary wing--Ú.
- Unknown fixed wing--U.
- Friendly rotary wing--Ó.
- Friendly fixed wing--O.

An available alarm, when enabled, will sound to alert the operator when the first unknown target is displayed. The alarm sounds only for the first unknown target and will not sound again until the screen has been cleared.

[Figure H-10.](#)

TARGET LOCATION

A target symbol is placed at its correct range and azimuth on the grid display. This is determined by the target's location within the 10-kilometer grid which is subdivided into 1-kilometer divisions. Each symbol will remain at this location for one complete antenna rotation, (6-second rotation) and will be erased from the display when the antenna passes its position on the next rotation. If the sensor detects the same target on the next revolution, the target symbol will be displayed at the new position. The sensor operator will continue to plot and report target data until either the aircraft is destroyed or passes out of

sensor coverage range.

SCENARIO

The following scenario is an example of how sensors would disseminate MSCS data by using directed EW to an ADA battery or platoon (versus the usual doctrine of sending all EW tracks to the ABMOC). The sensor has been operationally deployed and is providing sensor coverage for a task force operation (attached to an ADA battery commander). Suddenly, the sensor detects an unknown fixed-wing aircraft ingressing from the north at a range of 20 kilometers. At the CIU, the unknown fixed wing is shown on the grid display in grid square "KELLOG 1-9" (see the Operator's CIU Display illustration below). The sensor operator immediately reports the MSCS EW information presented on the FAAD grid display to the battery/platoon CP. The operator uses the MSCS procedures outlined in this chapter. The section chief, as directed by local TSOP, disseminates directed EW to the nearest ADA fire units on their FM platoon command net. At the platoon CP, the platoon leader receives the MSCS data and plots it on the 1:50,000 map. The map contains not only the MSCS grid squares, and battlefield graphics, but also the locations and PTLs of the platoon's fire units. The platoon leader determines that the aircraft's flight path is heading in the general direction of "NAI ONE" (see the illustration on page H-12). Using the platoon FM command net, the platoon leader broadcasts a directed early warning message, "Dynamite, Dynamite, unknown fixed-wing ingressing north of NAI ONE." At the fire units, NAI ONE's location is identified on the situation map. The observers and gunners then concentrate their search procedures towards NAI ONE and the ingressing aircraft's general direction. They apply the search and scan and engagement procedures described in FMs 44-31 and 44-44 (TBP).

[Figure H-11.](#)

[Figure H-12.](#)

DIVISION EARLY WARNING BROADCAST NET

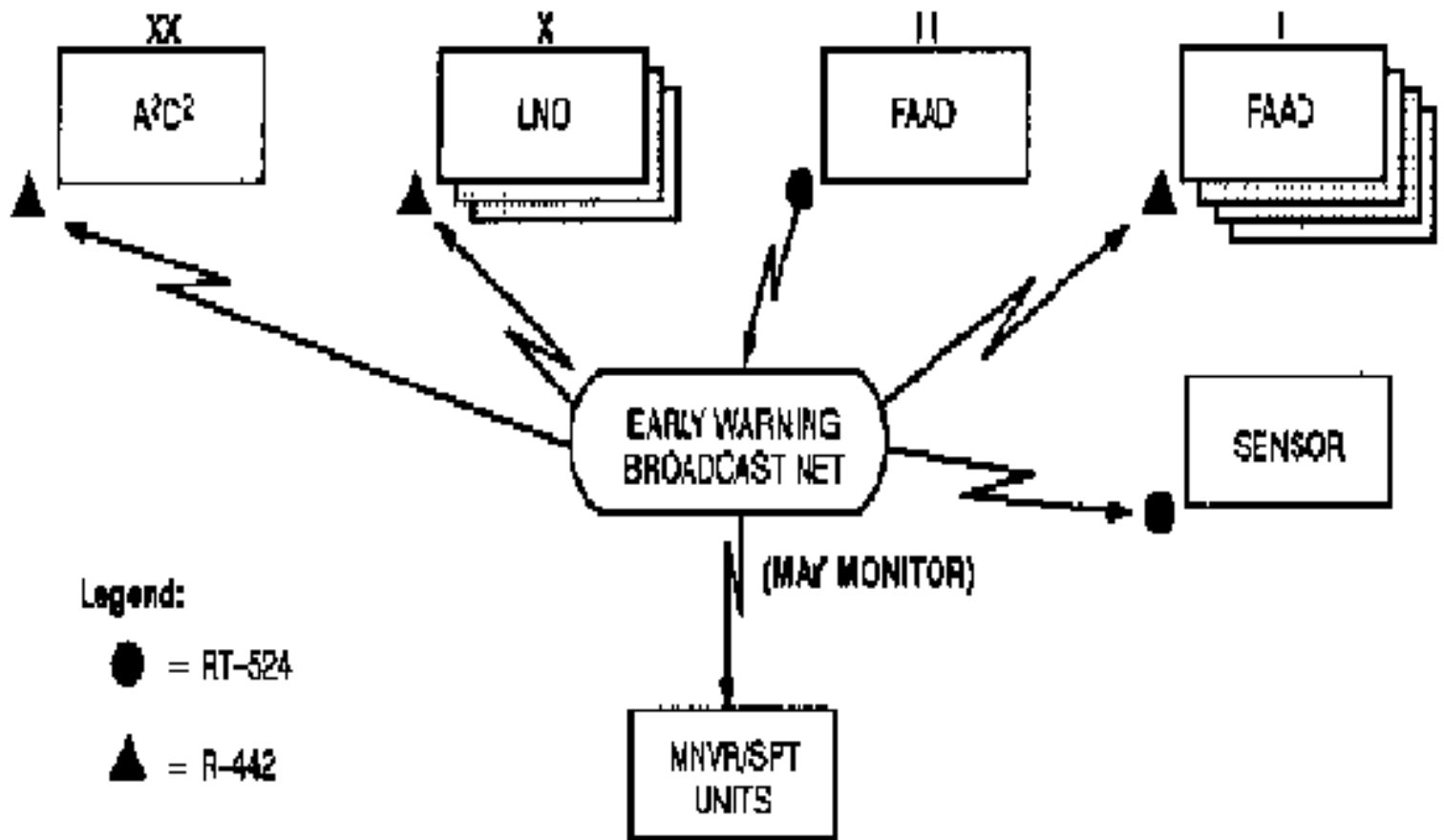

Figure H-1

TRACK PLOTTING

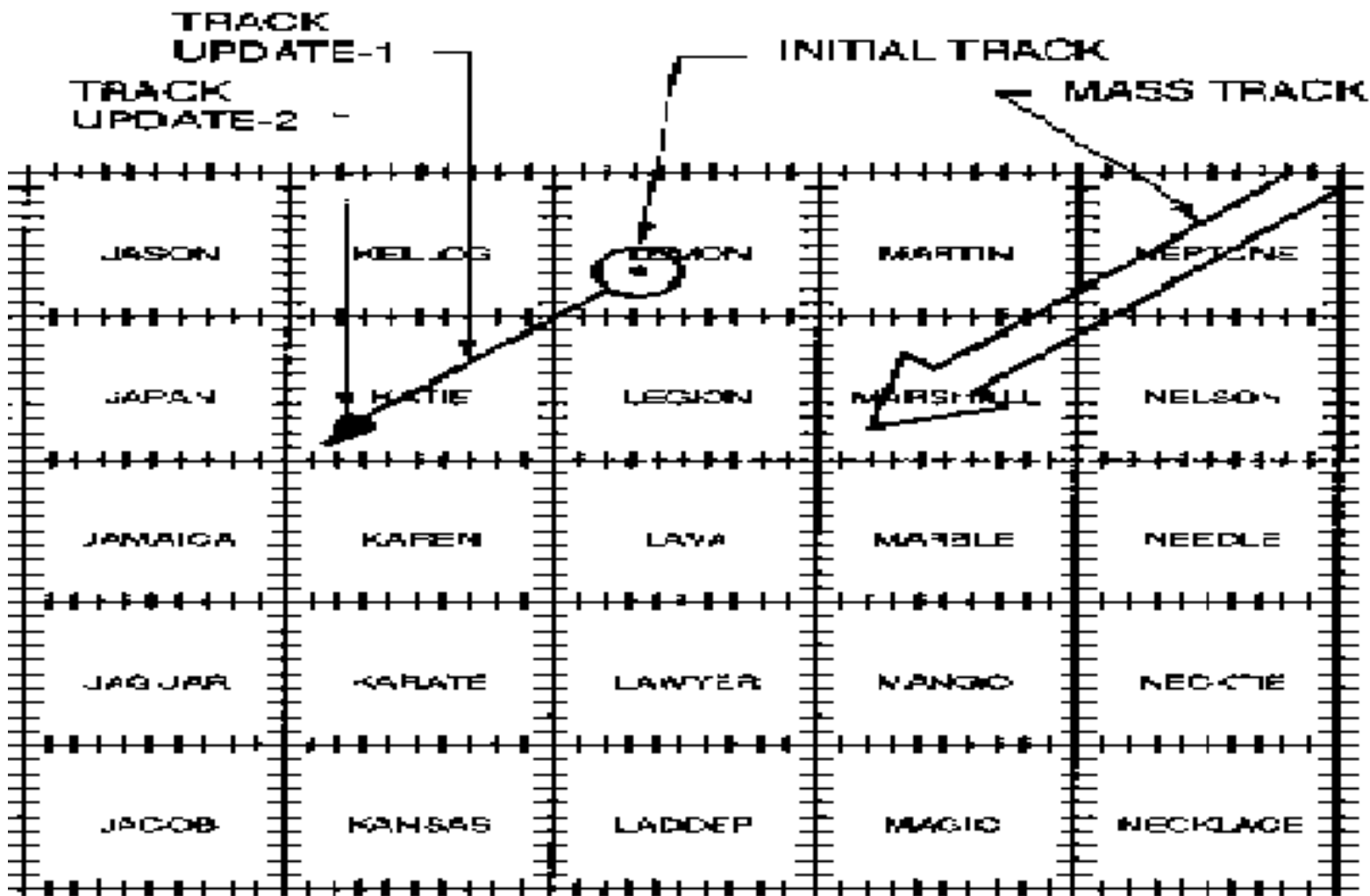

Figure H-3

FAAD GRID EXAMPLE

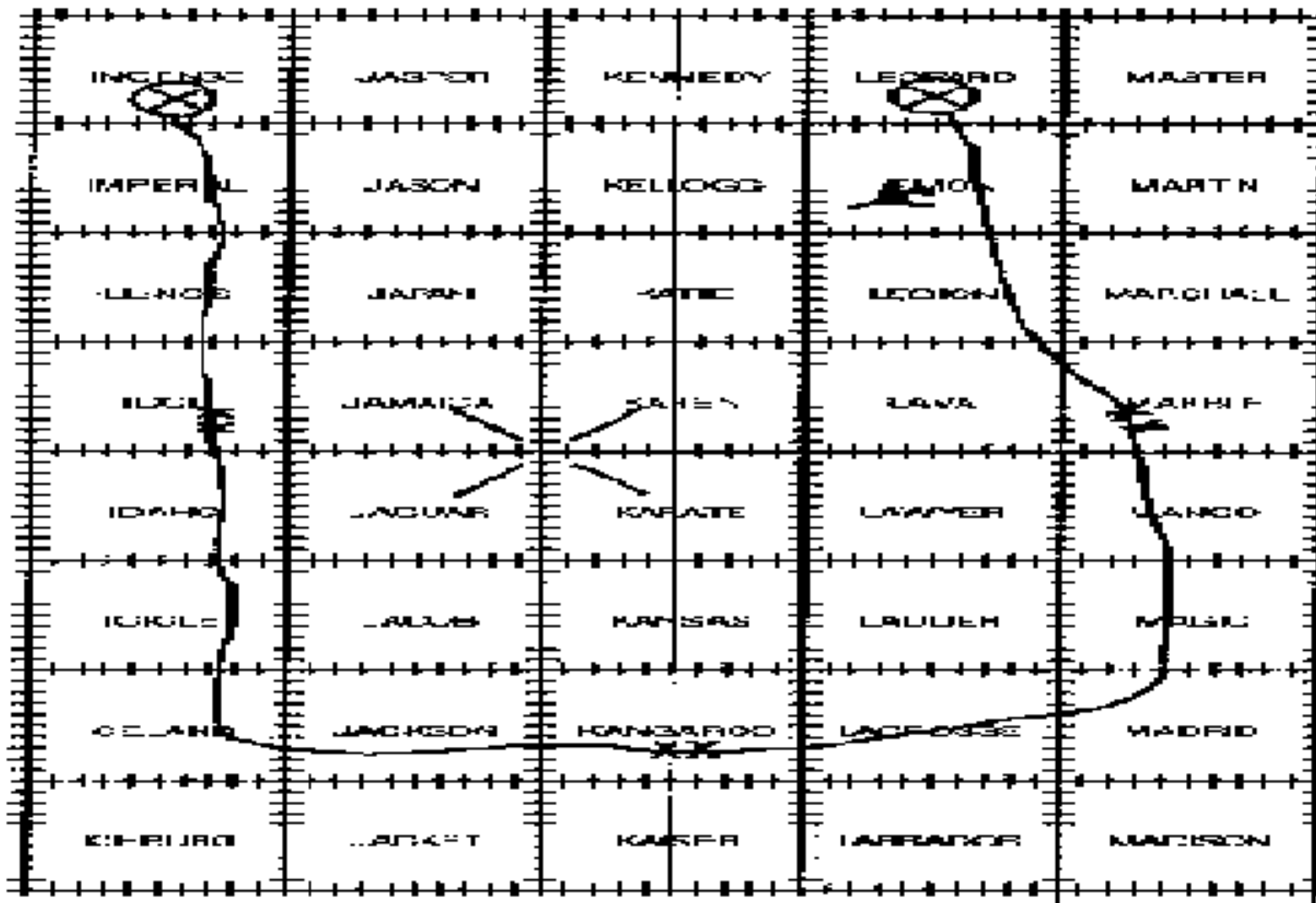

Figure H-4

TRACK REPORT EXAMPLES

Initial Track

When transmitting an "Initial Track," all known information should be transmitted as time or the tactical situation permits. Using the example shown, an initial track report would be—

INITIAL TRACK, INITIAL TRACK
UNKNOWN
AT LEMON-THREE-THREE
HEADING SOUTHWEST
ONE
JFT
TRACK DESIGNATOR ALPHA-ZERO-ONE

Track Update-1

To transmit a track update, only the prefix, the track designator, the new location, and the new heading must be sent. Using the example shown, if the aircraft moved to grid Katie and is located at Katie 7 7, the track update report would be

TRACK UPDATE
ALPHA ZERO ONE
NOW AT KATIE-SEVEN-SEVEN
HEADING SOUTHWEST

Track Update-2 (Identified)

Track update reports must also include any changes in the information previously reported. For instance, if, in the example shown, the aircraft is now identified as hostile and its new location is Katie-2-2, the track update report would be—

TRACK UPDATE
ALPHA ZERO ONE
NOW AT KATIE-TWO-TWO
NOW HOSTILE
HEADING SOUTHWEST

Note: Track updates should be applied about twice a minute.

Scrub Track

A "Scrub Track" is reported when a track exits the area of interest. A track no longer appears on the radar screen being viewed, or is identified as friendly. To report a "Scrub Track," only the prefix and track designator must be transmitted. An example of a "Scrub Track" report would be—

SCRUB TRACK
ALPHA ZERO ONE

Mass Track

The last type of track report is a "Mass Track." A "Mass Track" is transmitted instead of an "Initial Track" when the track (raid size) is "Many." When reporting a "Mass Track," location will normally be one or more 10 km grid coordinates. Track updates for a "Mass Track" are transmitted only with track updates. An example of a "Mass Track" report would be—

MASS TRACK, MASS TRACK
HOSTILE
AT NOPTLINE AND MARSHALL
HEADING SOUTH EAST
MANY
JFT
TRACK DESIGNATOR ALPHA-ZERO-TWO

AIR DEFENSE FIRE COORDINATION SECTION

ABNOC

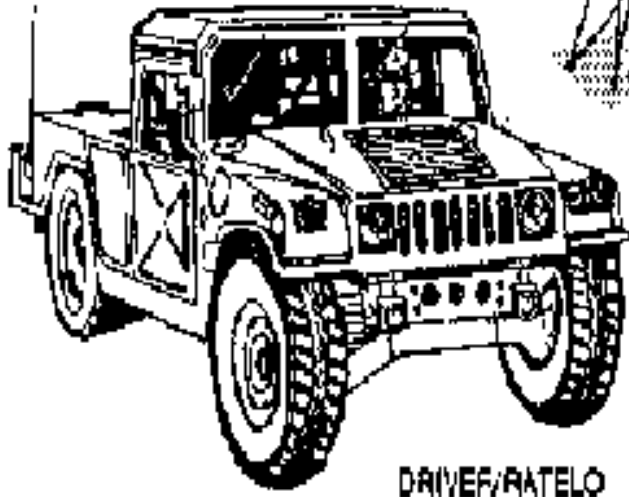

DRIVE/RATELO

OR



CRC

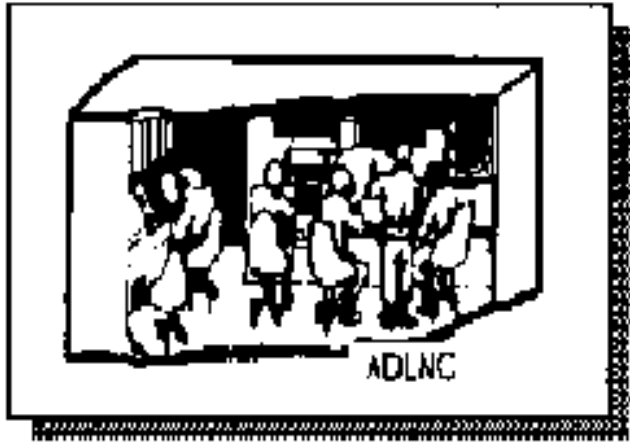

ADLNC

ADLNO CLIPBOARD MAP WITH FAAD GRID

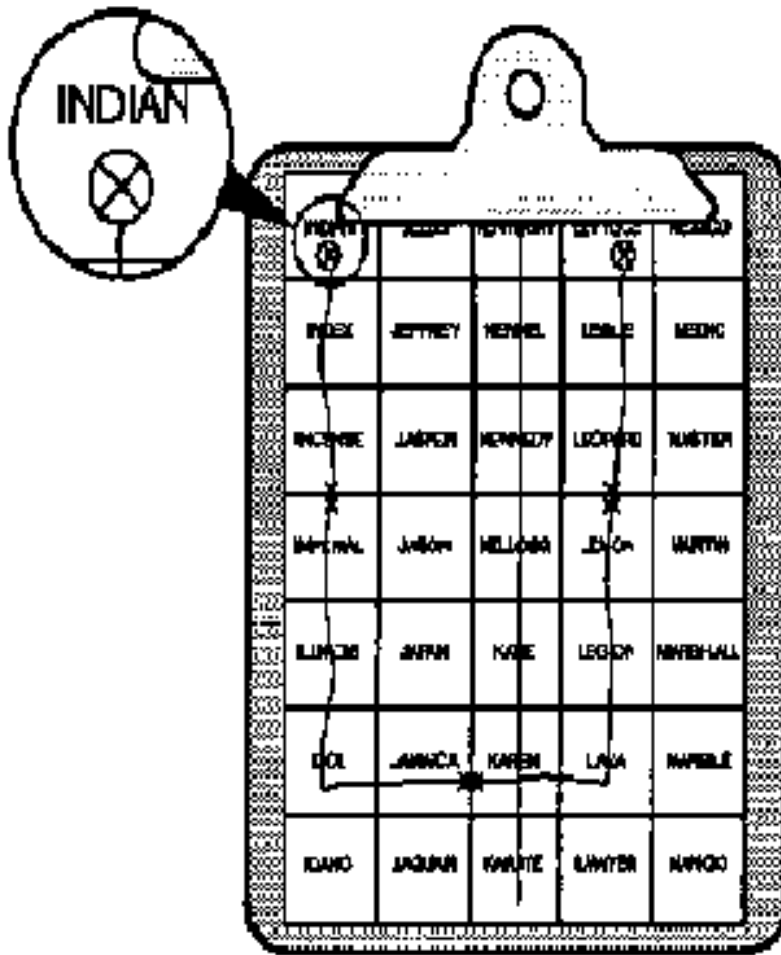

The ADLNO, viewing a radar console or manual plotting board, detects a hostile or unknown track either within, or approaching the division's area of operations. He notes the track's World Geographic Reference System (GEOREF) position and converts it to division grid position. For this purpose, the ADLNO has a clipboard-mounted map of the division's area of operations, marked with a unique FAAD grid of the division area of operation.

ADLNO CONVERSION OF GEOREF POSITION

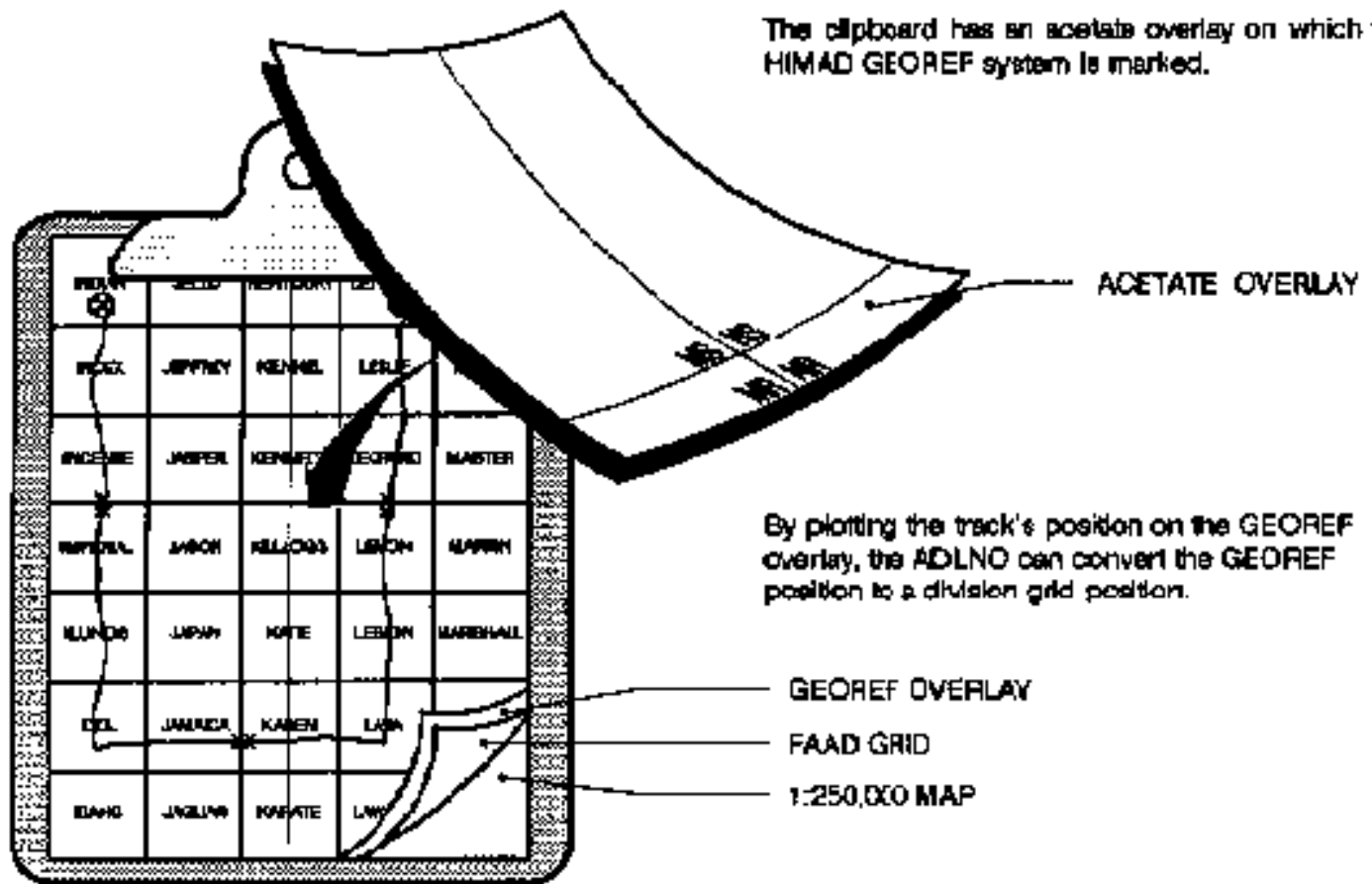

Figure H-8

MAP PLOTTING CASE

<table border="1" style="width: 100%; border-collapse: collapse;"> <tr><td style="text-align: center;">9</td><td style="text-align: center;">9</td><td style="text-align: center;">9</td></tr> <tr><td style="text-align: center;">8</td><td style="text-align: center;">8</td><td style="text-align: center;">8</td></tr> <tr><td style="text-align: center;">7</td><td style="text-align: center;">7</td><td style="text-align: center;">7</td></tr> <tr><td style="text-align: center;">6</td><td style="text-align: center;">6</td><td style="text-align: center;">6</td></tr> <tr><td style="text-align: center;">5</td><td style="text-align: center;">5</td><td style="text-align: center;">5</td></tr> <tr><td style="text-align: center;">4</td><td style="text-align: center;">4</td><td style="text-align: center;">4</td></tr> <tr><td style="text-align: center;">3</td><td style="text-align: center;">3</td><td style="text-align: center;">3</td></tr> <tr><td style="text-align: center;">2</td><td style="text-align: center;">2</td><td style="text-align: center;">2</td></tr> <tr><td style="text-align: center;">1</td><td style="text-align: center;">1</td><td style="text-align: center;">1</td></tr> <tr><td style="text-align: center;">2 3 4 5 6 7 8 9</td><td style="text-align: center;">2 3 4 5 6 7 8 9</td><td style="text-align: center;">2 3 4 5 6 7 8 9</td></tr> <tr><td style="text-align: center;">JASON</td><td style="text-align: center;">MELLOG</td><td style="text-align: center;">LEMON</td></tr> </table>	9	9	9	8	8	8	7	7	7	6	6	6	5	5	5	4	4	4	3	3	3	2	2	2	1	1	1	2 3 4 5 6 7 8 9	2 3 4 5 6 7 8 9	2 3 4 5 6 7 8 9	JASON	MELLOG	LEMON	<table border="1" style="width: 100%; border-collapse: collapse;"> <tr><td style="text-align: center;">9</td><td style="text-align: center;">9</td><td style="text-align: center;">9</td></tr> <tr><td style="text-align: center;">8</td><td style="text-align: center;">8</td><td style="text-align: center;">8</td></tr> <tr><td style="text-align: center;">7</td><td style="text-align: center;">7</td><td style="text-align: center;">7</td></tr> <tr><td style="text-align: center;">6</td><td style="text-align: center;">6</td><td style="text-align: center;">6</td></tr> <tr><td style="text-align: center;">5</td><td style="text-align: center;">5</td><td style="text-align: center;">5</td></tr> <tr><td style="text-align: center;">4</td><td style="text-align: center;">4</td><td style="text-align: center;">4</td></tr> <tr><td style="text-align: center;">3</td><td style="text-align: center;">3</td><td style="text-align: center;">3</td></tr> <tr><td style="text-align: center;">2</td><td style="text-align: center;">2</td><td style="text-align: center;">2</td></tr> <tr><td style="text-align: center;">1</td><td style="text-align: center;">1</td><td style="text-align: center;">1</td></tr> <tr><td style="text-align: center;">2 3 4 5 6 7 8 9</td><td style="text-align: center;">2 3 4 5 6 7 8 9</td><td style="text-align: center;">2 3 4 5 6 7 8 9</td></tr> <tr><td style="text-align: center;">JAPAN</td><td style="text-align: center;">KATIX</td><td style="text-align: center;">LEGION</td></tr> </table>	9	9	9	8	8	8	7	7	7	6	6	6	5	5	5	4	4	4	3	3	3	2	2	2	1	1	1	2 3 4 5 6 7 8 9	2 3 4 5 6 7 8 9	2 3 4 5 6 7 8 9	JAPAN	KATIX	LEGION	<table border="1" style="width: 100%; border-collapse: collapse;"> <tr><td style="text-align: center;">9</td><td style="text-align: center;">9</td><td style="text-align: center;">9</td></tr> <tr><td style="text-align: center;">8</td><td style="text-align: center;">8</td><td style="text-align: center;">8</td></tr> <tr><td style="text-align: center;">7</td><td style="text-align: center;">7</td><td style="text-align: center;">7</td></tr> <tr><td style="text-align: center;">6</td><td style="text-align: center;">6</td><td style="text-align: center;">6</td></tr> <tr><td style="text-align: center;">5</td><td style="text-align: center;">5</td><td style="text-align: center;">5</td></tr> <tr><td style="text-align: center;">4</td><td style="text-align: center;">4</td><td style="text-align: center;">4</td></tr> <tr><td style="text-align: center;">3</td><td style="text-align: center;">3</td><td style="text-align: center;">3</td></tr> <tr><td style="text-align: center;">2</td><td style="text-align: center;">2</td><td style="text-align: center;">2</td></tr> <tr><td style="text-align: center;">1</td><td style="text-align: center;">1</td><td style="text-align: center;">1</td></tr> <tr><td style="text-align: center;">2 3 4 5 6 7 8 9</td><td style="text-align: center;">2 3 4 5 6 7 8 9</td><td style="text-align: center;">2 3 4 5 6 7 8 9</td></tr> <tr><td style="text-align: center;">JAMAICA</td><td style="text-align: center;">KAREN</td><td style="text-align: center;">LAVA</td></tr> </table>	9	9	9	8	8	8	7	7	7	6	6	6	5	5	5	4	4	4	3	3	3	2	2	2	1	1	1	2 3 4 5 6 7 8 9	2 3 4 5 6 7 8 9	2 3 4 5 6 7 8 9	JAMAICA	KAREN	LAVA
9	9	9																																																																																																			
8	8	8																																																																																																			
7	7	7																																																																																																			
6	6	6																																																																																																			
5	5	5																																																																																																			
4	4	4																																																																																																			
3	3	3																																																																																																			
2	2	2																																																																																																			
1	1	1																																																																																																			
2 3 4 5 6 7 8 9	2 3 4 5 6 7 8 9	2 3 4 5 6 7 8 9																																																																																																			
JASON	MELLOG	LEMON																																																																																																			
9	9	9																																																																																																			
8	8	8																																																																																																			
7	7	7																																																																																																			
6	6	6																																																																																																			
5	5	5																																																																																																			
4	4	4																																																																																																			
3	3	3																																																																																																			
2	2	2																																																																																																			
1	1	1																																																																																																			
2 3 4 5 6 7 8 9	2 3 4 5 6 7 8 9	2 3 4 5 6 7 8 9																																																																																																			
JAPAN	KATIX	LEGION																																																																																																			
9	9	9																																																																																																			
8	8	8																																																																																																			
7	7	7																																																																																																			
6	6	6																																																																																																			
5	5	5																																																																																																			
4	4	4																																																																																																			
3	3	3																																																																																																			
2	2	2																																																																																																			
1	1	1																																																																																																			
2 3 4 5 6 7 8 9	2 3 4 5 6 7 8 9	2 3 4 5 6 7 8 9																																																																																																			
JAMAICA	KAREN	LAVA																																																																																																			
																																																																																																					
<table border="1" style="width: 100%; border-collapse: collapse;"> <tr><th colspan="4" style="text-align: center;">STATUS</th></tr> <tr><td style="width: 25%;"></td><td style="width: 25%;"></td><td style="width: 25%;"></td><td style="width: 25%;"></td></tr> <tr><td></td><td></td><td></td><td></td></tr> <tr><td></td><td></td><td></td><td></td></tr> <tr><td></td><td></td><td></td><td></td></tr> <tr><th colspan="3"></th><th style="text-align: center;">REMARKS</th></tr> <tr><td></td><td></td><td></td><td></td></tr> <tr><td></td><td></td><td></td><td></td></tr> <tr><td></td><td></td><td></td><td></td></tr> </table>			STATUS																							REMARKS																																																																											
STATUS																																																																																																					
			REMARKS																																																																																																		
<table border="1" style="width: 100%; border-collapse: collapse;"> <tr><th style="text-align: left;">INSTRUCTIONS</th></tr> <tr><td style="height: 100px;"></td></tr> </table>		INSTRUCTIONS		<table border="1" style="width: 100%; border-collapse: collapse;"> <tr><th style="text-align: left;">INSTRUCTIONS</th></tr> <tr><td style="height: 100px;"></td></tr> </table>	INSTRUCTIONS																																																																																																
INSTRUCTIONS																																																																																																					
INSTRUCTIONS																																																																																																					

Figure H-9

MAP/PLOTTING CASE

The map plotting case consists of a 9x9 grid with names in each cell. The names are: Jason, Kellog, Lenon (top row); Jason, **KATIE** (with a circled pencil icon), Legion (middle row); Jamaica, Karen, Laja (bottom row). The grid has coordinate markers 1-9 on both axes.

Administrative sections on the right include:

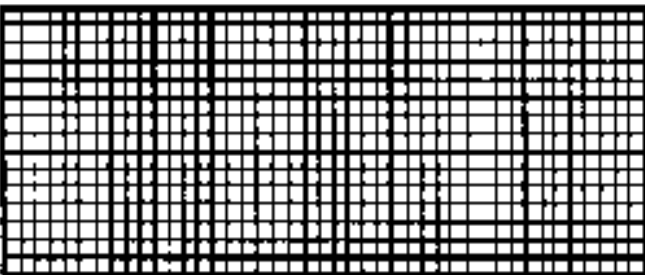
- A large empty grid at the top right.
- A **STATUS** table with 3 columns and 4 rows.
- A **REMARKS** table with 4 columns and 2 rows.
- A **INSTRUCTIONS** box with a wavy line pattern.

Figure H-10

OPERATOR'S CIU DISPLAY

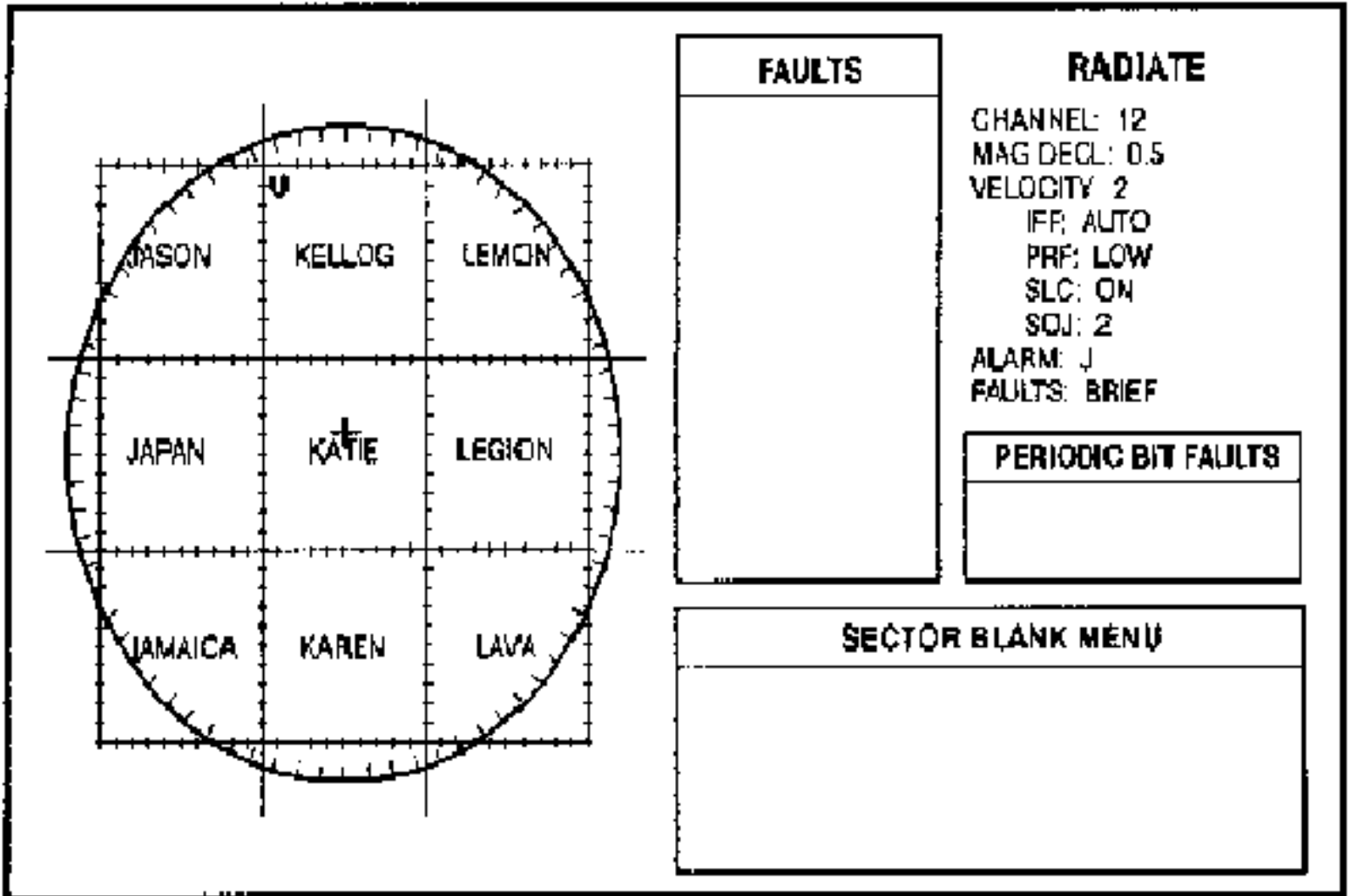
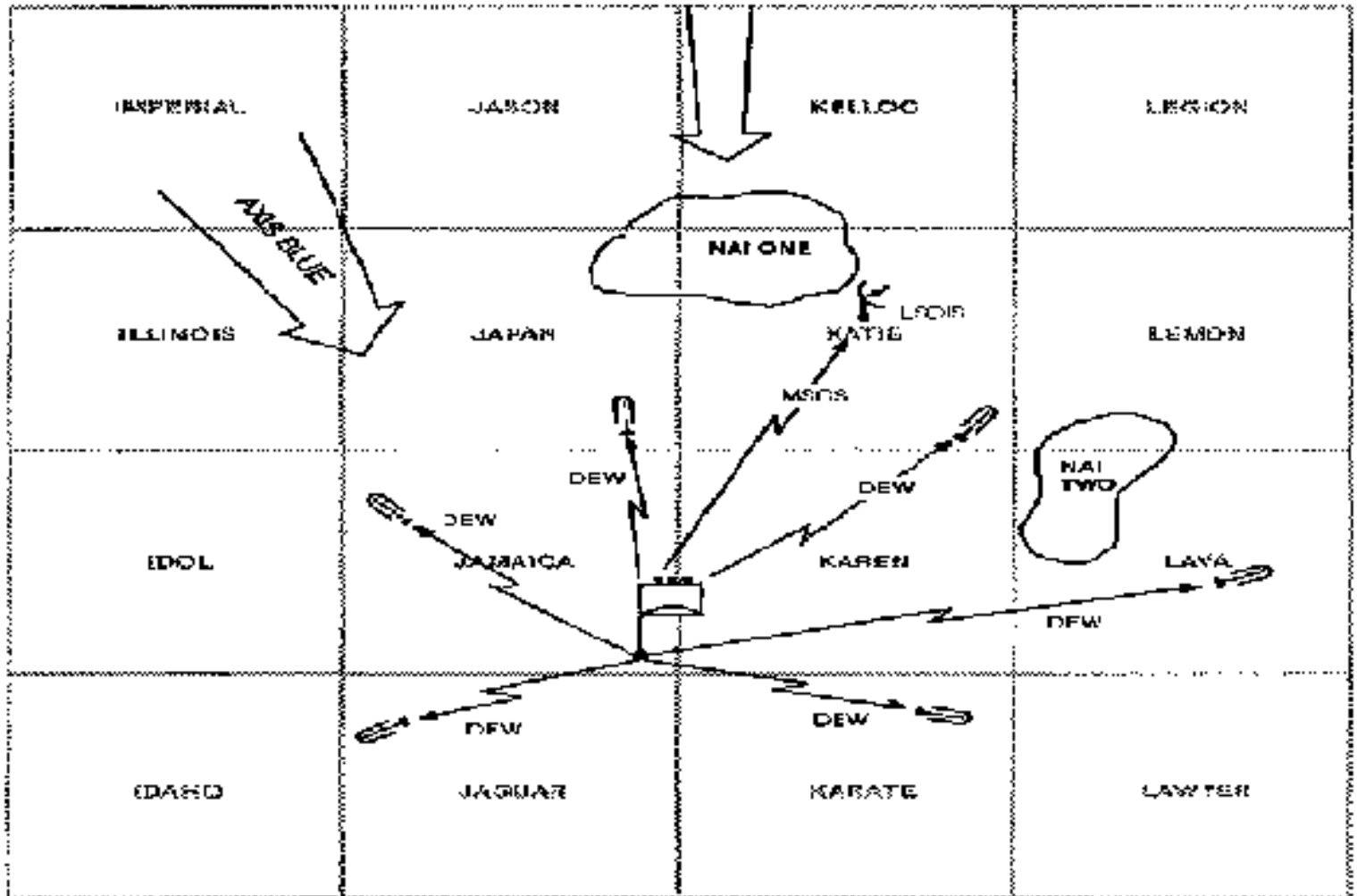

Figure H-11

PLATOON LEADER'S OVERLAY



Note: Not drawn to scale.

Figure H-12

Glossary

A2C2

Army Airspace Command and Control

AA

size of battery

AAA

air avenue of approach

AAM

air to air missile

ABMOC

Air Battle Management Operations Center

active air defense

direct defensive action taken to destroy attacking enemy aircraft or missiles or to nullify or reduce the effectiveness of such attack. It includes such measures as the use of aircraft, interceptor missiles, air defense weapons artillery, non-air defense weapons in an air defense role, and electronic countermeasures and counter-countermeasures. (JCS Pub 1-02)

AD

air defense

ADA

air defense artillery

ADCN

air defense coordination net

ADCOORD

air defense coordinator

ADCS

air defense coordination section

ADFCS

air defense fire coordination section

ADLNO

air defense liaison officer

ADW

air defense warning

AH

attack helicopter

air battle management

a fundamental task of air defense command and control and airspace management which encompasses the principles for the control and coordination of both tactical air and ground-based air defense resources. Air battle management is exercised through positive and procedural methods.

air corridor

a restricted air route of travel specified for use by friendly aircraft and established for the purpose of preventing friendly aircraft from being fired upon by friendly forces.

air defense (AD)

all measures designed to nullify or reduce the effectiveness of attack by hostile aircraft or guided missiles both before and after they are airborne.

air defense artillery (ADA)

ground-based, surface-to-air weapons, including guns and surface-to-air missiles and support equipment, for engaging air targets.

air recon

aerial reconnaissance

airspace control

a service provided in the combat zone to increase operational effectiveness by promoting the safe, efficient, and flexible use of airspace. Airspace control is provided to permit greater flexibility of operations, while authority to approve, disapprove, or deny combat operations is vested only in the

operational commander.

airspace management

the coordination, integration, and regulation of the use of airspace of defined dimensions.

air strike

an attack on specific objectives by fighter, bomber, or attack aircraft on an offensive mission.

A/L

administrative/logistics

ALB

AirLand Battle

alert

a warning signal of a real or threatened danger, such as an air attack; to forewarn; to prepare for action.

allocation

(1) the translation of the apportionment into total number of sorties by aircraft type available for each operation task and (2) an apportionment of a definite quantity of supplies, space, services, personnel, or productive facility for a specific use.

alt

altitude

alternate position

the position given to a weapon, unit, or individual to be occupied when the primary position becomes untenable or unsuitable for carrying out its task. The alternate position is located so that the weapon can continue to fulfill its original task.

AM

amplitude modulation

AMC

at my command--a method of control for fire support

AMO

air movement officer

ant

antenna

AO

area of operations

AP

armor piercing

area air defense commander

within an overseas unified command, subordinate unified command, or joint task force, the commander will assign overall responsibility for air defense to a single commander. Normally, this will be the Air Force component commander. Representation from the other service components involved will be provided, as appropriate, to the area air defense commander's headquarters.

ARM

antiradiation missile

ASM

air-to-surface missile aim smart munitions

ASP

ammunition supply point

AT

antitank

ATGM

antitank guided missile

attach

the placement of units or personnel in an organization where such placement is relatively temporary. Subject to limitations imposed by the attachment order, the commander of the formation, unit, or organization receiving the attachment will exercise the same degree of command and control thereover as he does over units and persons organic to his command. However, the responsibility for transfer and promotion of personnel will normally be retained by the parent formation, unit, or organization.

attack

an offensive action characterized by fire and

maneuver and culminating in a violent assault or, in an attack by fire, in the delivery of intensive direct fires from an advantageous position. Its purpose is to direct a decisive blow at the enemy to hold him, destroy him in place, or force him to capitulate.

attn

attention

AWACS

Airborne Warning and Control System

BAI

battlefield air interdiction

basic load (ammunition)

that quantity of nonnuclear ammunition that is authorized and required by each service to be on hand a unit to meet combat needs until resupply can be accomplished. It is expressed in rounds, units, or units of weight as appropriate.

batt

battery

battle position

positions on which the main effort of the defense is concentrated. A battle position is made up of a system of defensive sectors that support one another.

battlefield operating system (BOS)

the major functions occurring on the battlefield and performed by the force to successfully execute operations. The seven systems are (1) maneuver, (2) fire support, (3) air defense, (4) command and control, (5) intelligence, (6) mobility and survivability, and (7) combat service support. NBC must be integrated throughout each BOS.

BC

battery commander

BCS

battery computing system

BCU

battery coolant unit

bde

brigade

bn

battalion

BNTOC

battalion tactical operations center

BOS

battlefield operating system

boundary

in land warfare, a line by which areas of responsibility between adjacent units/formations are defined.

bounding overwatch

a movement technique used when contact with enemy forces is expected. The unit moves by bounds. One element is always halted in position to overwatch another element while it moves. The overwatching element is positioned to support the moving unit by fire or fire and maneuver.

BSA

battalion support area

BSFV

Bradley Stinger Fighting Vehicle

btry

battery

CAAD

combined arms air defense

(c)

control

CAS

close air support

C2

command and control

C2I

command, control, and intelligence

C3

command, control, and communications

C3I

command, control, communications, and intelligence

close air support (CAS)

air action against hostile targets which are in proximity to friendly forces and which require detailed integration of each air mission with the fire and movement of those forces.

CB

common battery

CBS

common battery signaling system

CBU

cluster bomb unit

CFA

covering force area

CFF

call for fire

CIU

control indicator unit

cmd

command

collection plan

a plan that provides a framework used to determine and evaluate intelligence needs. It helps the commander to see as deep in space and time as possible.

combat support elements

those elements whose primary missions are to provide combat support to the combat forces and which are a part, or prepared to become a part, of a theater, command, or task force formed for combat operations.

combat trains

the portion of unit trains that provides the combat service support required for immediate response to the needs of forward tactical elements.

COMINT

communications intelligence

combat support

fire support and operational assistance provided to combat elements. It includes artillery, air defense artillery, aviation (less air cavalry and attack helicopter), engineer, military police, signal, military intelligence, and chemical.

combat service support

the essential logistics functions, activities, and tasks necessary to sustain all elements of an operating force in an area of operations. Combat service support includes, but is not limited to, the assistance provided operating forces primarily in the fields of administrative services, chaplain services, civil affairs, finance, legal services, health services, military police, supply, maintenance, transportation, construction, troop construction, acquisition and disposal of real property, facilities engineering, topographic and geodetic engineering functions, food service, graves registration, laundry, dry cleaning, bath, property disposal, and other logistics services.

command

the authority that a commander in the military service lawfully exercises over subordinates by virtue of rank or assignment. Command includes the authority and responsibility for effectively using available resources and for planning the employment of, organizing, directing, coordinating, and controlling military forces for the accomplishment of assigned missions. It also includes responsibility of health, welfare, morale, and discipline or assigned personnel. (JCS Pub 1-02)

command and control

the exercise of authority and direction by a properly designated commander over assigned

forces in the accomplishment of the mission.

Command and control functions are performed through an arrangement of personnel, equipment, communications, facilities, and procedures employed by a commander in planning, directing, coordinating, and controlling forces and operations in the accomplishment of the mission (JCS Pub 1-02).

command post

a unit's or subunit's headquarters where the commander and the staff perform their activities. In combat, a unit's or subunit's headquarters is often divided into echelons; the echelon in which the unit or subunit commander is located or from which he operates is called a command post.

communications security

the protection resulting from all measures designed to deny unauthorized persons information of value which might be derived from the possession and study of telecommunications, or to mislead unauthorized persons in their interpretation of the results of such possession and study.

continuity

continuity implies the responsibility of ensuring an operation is not affected by an interruption of support or by unforeseen events.

control

authority that may be less than full command exercised by a commander over part of the activities of subordinate or other organizations.

COSCOM

corps support command

counterair operations

air operations conducted to attain and maintain a desired degree of air superiority by the destruction or neutralization of enemy forces.

Both offensive and defensive actions are involved.

The former range throughout enemy territory and

are generally conducted at the initiative of friendly forces. The latter are normally conducted near or over friendly forces and are generally reactive to the initiative of the enemy air forces.

CP

command post

CRC

control and reporting center

CRP

control and reporting post

CS

combat support

CSS

combat service support

cueing

providing specific and timely position data with tentative identification of aircraft within a designated range of a fire unit.

CY

calendar year

DA

Department of the Army

DAG

division artillery group

DC

District of Columbia (Washington)

decisive engagement

an engagement in which a unit is considered fully committed and cannot maneuver or extricate itself. In the absence of outside assistance, the action must be fought to a conclusion and either won or lost with the forces at hand.

defend

a mission assigned to a unit which requires it to destroy an attacking enemy force or stop it from penetrating the assigned sector or battle position. Subunits of the defending unit may have such

missions as defend, delay, or counterattack.

DEW

division early warning

div

division

DISCOM

division support command

DP

decision point

DS

direct support

DSM

decision support matrix

DST

decision support template

DSU

direct support unit

DTAC

division tactical (operations center)

DTG

date-time group

DZ

drop zone

E

east

ea

each

early warning (EW)

early notification of the launch or approach of unknown weapons or weapon carriers.

ECCM

electronic counter-countermeasures

ECM

electronic countermeasures

EEI

essential elements of information

electronic warfare

military action involving the use of electromagnetic energy to determine, exploit, reduce, or prevent hostile use of the electromagnetic spectrum and action which retains friendly use of electromagnetic spectrum.

ELINT

electronic intelligence

electronic counter-countermeasures (ECCM)

that division of electronic warfare involving actions taken to ensure friendly effective use of the electromagnetic spectrum despite the enemy's use of electronic warfare.

electronic countermeasures (ECM)

that division of electronic warfare involving actions taken to prevent or reduce an enemy's effective use of the electromagnetic spectrum.

EMCON

emission control

engage

in air defense, a fire control order used to direct or authorize units and or weapon systems to fire on a designated target.

engagement area

(killing area or zone) an area in which a commander plans to force the enemy to concentrate so as to destroy him with conventional weapons.

EWBN

early warning broadcast net

EW

early warning

F

frequency

FA

field artillery

FAA

forward alighting area

FAAD

forward area air defense

FAAR

forward area alerting radar

FAC

forward air controller

FACP

forward air control post

FARP

forward area rearm/refuel point

FDC

fire direction center

FDO

fire direction officer

FEBA

forward edge of the battle area

FFE

fire for effect

field of fire

the area which a weapon or group of weapons may cover effectively with fire from a given position.

field trains

the portion of the unit trains that provides the combat service support not required for immediate response to the needs of tactical elements. They are located rearward to prevent interference with the tactical operation. Field trains, displaced independently from the supported tactical unit, achieve security through passive measures.

fire and maneuver

tactical technique, usually an extension of bounding overwatch, used once contact with the enemy is gained. One element moves while another provides a base of fire.

fire support coordination line (FSCL)

a line established by the

appropriate ground commander to ensure coordination of fire not under his control but which may affect current tactical operations. The fire support coordination line is used to coordinate fires of air, ground, or sea weapons systems using any type of ammunition against surface targets. The FSCL should follow well-defined terrain features.

fire support coordinator

the senior field artillery officer at each echelon above maneuver platoon level who serves as the principal advisor to the commander for the planning and coordination of all available fire support.

fire support element (FSE)

a functional portion of a force tactical operations center that provides centralized targeting, coordination, and integration of fires, delivered by fire support means under the control of, or in support of, the force on surface targets.

fire support team (FIST)

in fire support operations, a team comprised of a team chief (FA lieutenant) and the necessary additional personnel and equipment required to request, coordinate, and direct fire support efforts for company-size units.

FIST

fire support team

FLOT

forward line of own troops

forward line of own troops (FLOT)

a line which indicates the most forward positions of friendly forces in any kind of military operation at a specific time.

fluid

events easily changed or tending to change.

FM

frequency modulation field manual

FO

forward observer

forward area rearm and refuel point (FARP)

a temporary facility organized, equipped, and deployed by an aviation unit commander and normally located closer to the area of operation than the aviation unit's combat service area to provide fuel and ammunition necessary for the employment of helicopter units in combat. The forward arming and refueling point permits combat aircraft to rapidly refuel and rearm simultaneously.

forward edge of the battle area (FEBA)

the foremost limits of a series of areas in which ground combat units are deployed, excluding the areas in which the covering or screening forces are operating, designated to coordinate fire support, the positioning of forces, or the maneuver of units.

FPF

final protection fires

FPL

final protective line

FRAGO

fragmentary order

fragmentary order (FRAGO)

an abbreviated form of an operation order, usually issued on a day-to-day basis, that eliminates the need for restating information contained in a basic operation order. It may be issued in sections.

FSCL

fire support coordination line

FSE

fire support element

ft

foot

FU

fire unit

FW

fixed wing

GBS

ground-based sensor

GMET

graphical munitions effectiveness table

GN

grid north

GOAR

ground observer aircraft recognition

GEOREF

World Geographic Reference System

GS

general support

GSR

general support reinforcing

G2

division intelligence officer

G3

division operations officer

GTA

graphic training aid

HE

high explosives

hel

helicopter

HF

high frequency

HHB

headquarters and headquarters battery

HHC

headquarters and headquarters company

HIMAD

high- to medium-altitude air defense

HMMWV

high-mobility multipurpose wheeled vehicle

hostile criteria

description of conditions under which an aircraft or vehicle may be identified as hostile for engagement purposes.

Hz

hertz

ICM

improved capabilities missile

ICOM

integrated communications security

ID

identification

identification, friend, or foe (IFF)

a system using electromagnetic transmissions which equipment carried by friendly forces automatically responds; for example, by emitting pulses, thereby distinguishing themselves from enemy forces.

IFF

identification, friend, or foe

improvisation

the art of continuing effective operations in unusual circumstances or in a degraded mode, it is the ability to react to the unanticipated.

indirect fire

fire delivered on a target that is not itself used as a point of aim for the weapons or the director.

insertion

(1) placement of troops and equipment into an operational area in airmobile operations; and (2) the placement of observation posts, patrols, or raiding parties either by helicopter or parachute.

INT-EXT

internal and external

intelligence preparation of the battlefield (IPB)

a continuous, integrated, and comprehensive analysis of the effects of terrain, weather, and enemy capabilities on

operations. Using overlays, graphic displays, and templating techniques, the IPB process increases the accuracy and timeliness of the intelligence available to the commander. It should start well before combat operations begin.

IPB

intelligence preparation of the battlefield

IRS

infrared seeker

jamming

the deliberate radiation, reradiation, or reflection of electromagnetic energy to prevent or degrade the receipt of information by a receiver. It includes communications jamming and noncommunications jamming.

JMEM

joint munitions effectiveness manual

kHz

kilohertz

kw

kilowatt

km

kilometer

LADW

local air defense warning

LAW

light antitank weapon

LB

local battery

ldr

leader

LG

laser guided

liaison

that contact or intercommunications maintained between elements of military forces to ensure

mutual understanding and unity of purpose and effort.

LIN

line item number

linkup

a meeting of friendly ground forces (such as when an advancing force reaches an objective area previously seized by an airborne or air assault force; when an encircled element breaks out to rejoin friendly forces; or when converging maneuver forces meet).

linkup point

an easily identifiable point on the ground where two forces conducting a linkup meet. When one force is stationary, linkup points normally are established where the moving force's routes of advance intersect the stationary force's security elements. Linkup points for two moving forces are established on boundaries where the two forces are expected to converge.

LNO

liaison officer

logistics package

(LOGPAC) a daily resupply of normally Classes I,III, and V as well as medical and ADA-peculiar items

LOGPAC

logistics package

LOS

line of sight

LP

listening post

LSDIS

light and special divisions interim sensor

LSI

large scale integration

LZ

landing zone

m

meter

mm

millimeter

MACLOS

manual control to line of sight

mag decl

magnetic north declination

main attack

the principal attack or effort into which a commander throws the full weight of the offensive combat power at his disposal. An attack directed against the chief objective of the campaign or battle.

MANPADS

man-portable air defense system

mask clearance

(1) the absence of any obstruction in the path of a trajectory; and (2) the amount of clearance by which a projectile passes over any object between the weapon and its target.

METT-T

mission, enemy, terrain, troops, and time available

MEWN

manual early warning network

mi

miles

MHz

megahertz

mnvr

maneuver

MOPP

mission-oriented protection posture

movement technique

manner of traversing terrain (for example, traveling, traveling overwatch, and bounding overwatch). The likelihood of enemy contact determines which technique is used.

movement to contact

an offensive operation designed to gain initial ground contact with enemy or to regain lost contact. (In NATO, the term "advance to contact" is used.)

MP

manpack

MPH

miles per hour

MRE

meals, ready-to-eat

MSCS

manual SHORAD control system

msl

missile

mutual support

that support which units render each other against an enemy, because of their assigned tasks, their position relative to each other and to the enemy, and their inherent capabilities.

N

north

N/A

not applicable

NAI

named area of interest

NATO

North Atlantic Treaty Organization

NBC

nuclear, biological, chemical

NCS

net control station

NDP

night defensive position

NE

northeast

NOE

nap of the earth

NSN

national stock number

NVD

night vision device

NVIS

near vertical incidence sky-wave antenna

obscuration fire

a category of fire using smoke or other obscurants directly on or near the enemy with the primary purpose of suppressing observers and minimizing the enemy's vision both within and beyond their position area.

OCOKA

observation and fields of fire, cover and concealment, obstacles, key terrain, and avenues of approach

OIC

officer in charge

OP

observation post

OPCOM

operational command

OPCON

operational control

operation overlay

overlay showing the location and strength of friendly forces involved in an operation. It may indicate predicted movements and locations of enemy forces. It is usually substituted for an operation map at the lower echelons as an essential part of an operation order.

operational command (OPCOM)

the authority granted to a commander to assign missions or tasks to subordinate commanders, to deploy units, to reassign forces, and to retain or delegate operational and or tactical control as may be deemed necessary. It does not of itself include responsibility for administration or logistics. May also be used to denote the

forces assigned to a commander.

operational control (OPCON)

transferable command authority which may be exercised by commanders at any echelon at or below the level of unified or specified combatant commands. It normally provides full authority to organize commands and forces and to employ those forces as the commander in operational control considers necessary to accomplish assigned missions. Operational control does not, in and of itself, include authoritative direction for logistics or matters of administration, discipline, internal organization, or unit training.

operation plan (OPLAN)

a plan for a single or series of connected operations to be carried out simultaneously or in succession. It is usually based upon stated assumptions and is the form of directive employed by higher authority to permit subordinate commanders to prepare supporting plans and orders. The designation "plan" is usually used instead of "order" in preparing for operations well in advance. An operation plan may be put into effect at a prescribed time, or on signal, and then becomes the operation order.

operation order (OPORD)

a directive issued by a commander to subordinate commanders for the purpose of effecting the coordinated execution of an operation.

OPLAN

operation plan

OPORD

operation order

overwatch

(1) a tactical technique in which one element is positioned to support the movement of another element with immediate direct fire, and (2) the

tactical role of an element positioned to support the movement of another element with immediate direct fire.

passage point

a place where units will pass through one another either in an advance or withdrawal. It is located where the commander desires subordinate units to physically execute a passage of lines.

passive air defense

all measures, other than active defense, taken to minimize the effects of hostile air action. These measures include the use of cover, concealment, camouflage, deception, dispersion, and the use of protective construction.

PDF

principal direction of fire

PEWS

platoon early warning system

PIR

priority intelligence requirement

plt

platoon

POL

petroleum, oils, and lubricants

pop-up-point

the location at which aircraft quickly gain altitude for target acquisition and engagement.

positive control

a method of airspace control that relies on positive identification, tracking, and direction of aircraft within an airspace, conducted with electronic means by an agency having this authority and responsibility therein.

PPI

plan position indicator

PRF

pulse repetition frequency

primary position

that location which provides the best means to

accomplish the assigned mission.

procedural control

a method of airspace control that relies on a combination of previously agreed and promulgated orders and procedures.

PSG

platoon sergeant

PSID

patrol seismic intrusive device

PTL

primary target line

pwr

power

PZ

pickup zone

R

reinforcing

RATELO

radiotelephone operator

RCG

radio command guided (antiradiation missile)

RDF

radio direction finding

remotely piloted vehicle (RPV)

an unmanned vehicle capable of being controlled from a distant location through a communications link. It is normally designed to be recoverable. See unmanned aerial vehicle.

REMS

remote sensor

responsiveness

the ability to meet changing requirements quickly.

RF

radio frequency

RH

radar homing

RISTA

reconnaissance, intelligence, surveillance, and target acquisition

ROE

rules of engagement

RP

release point

RPV

remotely piloted vehicle

R&S

reconnaissance and surveillance

R/T

receiver/transmitter

RTO

radiotelephone operator

rules of engagement (ROE)

directives issued by competent

military authority which delineate the circumstances

and limitations under which forces will initiate and

or continue combat engagements with other forces

encountered. In air defense, directives that

delineate the circumstances under which weapons may

fire at an aircraft. The right of self-defense is never denied.

RW

rotary wing

S

south

SACLOS

semiautomatic command to line of sight

SALUTE

size, activity, location, unit, time, and equipment

SAM

surface to air missile

SAP

solid armor piercing

SE

southeast

sec

section

S2

intelligence officer

S3

plans and operations officer

S4

logistics officer

SINGARS

single-channel ground and airborne radio system

SLAR

side-looking airborne radar

SLC

side lobe cancellor

SOI

signal operation instructions

SOJ

standoff jammer

SOP

standing operating procedure

SP

start point

spt

support

support area

a designated area in which combat service support elements, some staff elements, and other elements locate to support a unit.

supporting attack

an offensive operation carried out in conjunction with a main attack and designed to achieve one or more of the following: deceive the enemy, destroy or pin down enemy forces which could interfere with the main attack, control ground whose occupation by the enemy will hinder the main attack, or force the enemy to commit reserves prematurely or in an indecisive area.

suppression

temporary or transient degradation of the

performance of a weapons system, below the level needed to fulfill its mission objectives, by an opposing force.

surveillance

the systematic observation of aerospace, surface or subsurface areas, places, persons, or things, by visual, natural, electronic, photographic, or other means.

TACFIRE

tactical fire

TAI

target area of interest

tactical operations center (TOC)

an element within the main command post which consists of those staff activities involved in sustaining current operations and in planning future operations.

TASC

training and audiovisual support center

task organization

a temporary grouping of forces designed to accomplish a particular mission. Task organization involves the distribution of available assets to subordinate control headquarters by attachment or by placing assets in direct support or under the operational control of the subordinate.

TBP

to be published

TF

task force

TM

technical manual

TOC

tactical operations center

TOE

table of organization and equipment

TOT

time on target

traveling

a movement technique used when speed is necessary and contact with enemy forces is not likely. All elements of the unit move simultaneously with the unit leader located where he can best control.

traveling overwatch

a movement technique used when contact with enemy forces is possible. The lead element and trailing element are separated by a short distance which varies with the terrain. The trailing element moves at variable speeds and may pause for short periods to overwatch the lead element. It keys its movement to terrain and the lead element. It overwatches at a distance such that enemy engagement of the lead element will not prevent the trailing element from firing or moving to support the lead element.

TSOP

tactical standing operating procedure

TTP

tactics, techniques, and procedures

UAV

unmanned aerial vehicle

unmanned aerial vehicle (UAV)

an air vehicle that is remotely or automatically controlled. See remotely piloted vehicle.

u

unit

US

United States

USAADASCH

United States Army Air Defense Artillery School

USAF

United States Air Force

USMC

United States Marine Corps

USN

United States Navy

V

velocity

volts

VA

vertical angle

VACR

visual aircraft recognition

veh

vehicle

VHF

very high frequency

VDC

volts direct circuit

VT

variable time

W

wavelength

west

WCS

weapons control status

weapons control status (WCS)

the degree of fire control imposed upon Army units having an air defense mission in the combat zone. Weapons control status terms normally used are as follows: WEAPONS FREE, WEAPONS TIGHT, and WEAPONS HOLD.

weapon engagement zone

in air defense, airspace of defined dimensions within which the responsibility for engagement normally rests with a particular weapon system.

weapons control

the varying degrees of formal control an area defense commander exercises over all air defense weapons in his area of responsibility.

WEAPONS FREE

in air defense, a weapons control order imposing a status whereby weapons systems may be fired

at any target not positively recognized as friendly.

WEAPONS HOLD

in air defense, a weapons control order

imposing a status whereby weapons systems may be fired

in self-defense or in response to a formal order.

WEAPONS TIGHT

in air defense, a weapons control order

imposing a status whereby weapons systems may be

fired only at targets recognized as hostile.

WEFT

wing, engine, fuselage, tail

WP

white phosphorus

yd

yard

References

SOURCES USED

These are the sources quoted or paraphrased in this publication.

[FM 6-20](#). Fire Support in the AirLand Battle. 17 May 1988.

[FM 6-30](#). Tactics, Techniques, and Procedures for Observed Fire. 16 July 1991.

[FM 7-8](#). Infantry Rifle Platoon and Squad. 22 April 1992.

[FM 21-26](#). Map Reading and Land Navigation. 30 September 1987.

[FM 21-75](#). Combat Skills of the Soldier. 3 August 1984.

[FM 21-76](#). Survival. 5 June 1992.

FM 44-1. US Army Air Defense Artillery Employment. 9 May 1983 (Change 1, August 1984).

FM 44-31. Tactics, Techniques, and Procedures for Avenger Squad Operations. 13 June 1990.

[FM 44-44](#). Avenger Platoon/Squad. (TBP).

[FM 90-3](#). Desert Operations. 19 August 1977.

[FM 100-5](#). Operations. 5 May 1986.

[FM 101-5-1](#). Operational Terms and Symbols. 21 October 1985.

[STP 21-1-SMCT](#). Soldier's Manual of Common Tasks. Skill Level 1, 1 October 1990.

DOCUMENTS NEEDED

These documents must be available to the intended users of this publication.

DA Form 12-11-E. Subscription Numbers, Part V (FMs, MQSs, STPs, and TCs). March 1988.

DA Form 2028. Recommended Changes to Publications and Blank Forms. February 1974.

FM 44-63. FAAD/SHORAD Battalion Operations, Heavy Divisions. 31 March, 1992.

[FM 44-100](#). US Army Air Defense Operations. 22 November 1988.

READINGS RECOMMENDED

These readings contain relevant supplemental information.

[FM 6-121](#). Tactics, Techniques, and Procedures for Field Artillery Target Acquisition. 25 September 1990.

[FM 22-100](#). Military Leadership. 31 July 1990.

[FM 24-18](#). Tactical Single-Channel Radio Communications Techniques. 30 September 1987.

[FM 24-33](#). Communications Techniques: Electronic Counter-Countermeasures. 17 July 1990.

FM 24-35. Signal Operation Instructions "The SOI." 26 October 1990.

[FM 44-80](#). Visual Aircraft Recognition. 20 July 1993.

FM 44-81. Combined Arms Air Defense. (TBP).

GTA 44-2-5. Soviet and Warsaw Pact Forward Area Air (Poster).

GTA 44-2-6. Aircraft Recognition Playing Cards.

GTA 44-2-7. Military Markings You Should Know (Poster).

GTA 44-2-8. Free World Forward Area Aircraft (Poster).

TC 24-24. Signal Data References: Communications-Electronics Equipment. 30 October 1988.

FM 44-48
21 SEPTEMBER 1993

By Order of the Secretary of the Army:
Official:

GORDON R. SULLIVAN
General, United States Army
Chief of Staff

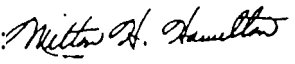
Official: 
MILTON H. HAMILTON
Administrative Assistant to the
Secretary of the Army
04855

Distribution:

Active Army, USAR, and ARNG: To be distributed in accordance with DA Form 12-11E, requirements for FM 44-48, Tactics, Techniques, and Procedures for the Sensor Platoon (Qty Rqr Block No. 4980)